

## **CONTENTS**

### **American National Standards**

|  |    |
|--|----|
| Project Initiation Notification System (PINS).....           | 2  |
| Call for Comment on Standards Proposals.....                 | 8  |
| Final Actions - (Approved ANS) .....                         | 18 |
| Call for Members (ANS Consensus Bodies) .....                | 22 |
| Accreditation Announcements (Standards Developers).....      | 27 |
| American National Standards (ANS) Process.....               | 29 |
| ANS Under Continuous Maintenance .....                       | 30 |
| ANSI-Accredited Standards Developer Contact Information..... | 31 |

### **International Standards**

|   |    |
|---|----|
| ISO and IEC Draft Standards .....                         | 34 |
| ISO and IEC Newly Published Standards .....               | 38 |
| International Organization for Standardization (ISO)..... | 42 |

### **Registration of Organization Names in the United States .....**

44

### **Proposed Foreign Government Regulations .....**

45

# Project Initiation Notification System (PINS)

ANSI Procedures require notification of ANSI by ANSI-accredited standards developers (ASD) of the initiation and scope of activities expected to result in new or revised American National Standards (ANS). Early notification of activity intended to reaffirm or withdraw an ANS and in some instances a PINS related to a national adoption is optional. The mechanism by which such notification is given is referred to as the PINS process. For additional information, see clause 2.4 of the ANSI Essential Requirements: Due Process Requirements for American National Standards.

Following is a list of proposed actions and new ANS that have been received recently from ASDs. Please also review the section in Standards Action entitled "American National Standards Maintained Under Continuous Maintenance" for additional or comparable information with regard to standards maintained under the continuous maintenance option. Use the following Public Document Library url to access PDF & EXCEL reports of approved & proposed ANS: [List of Approved and Proposed ANS](#)

Directly and materially affected interests wishing to receive more information or to submit comments are requested to contact the standards developer directly within 30 days of the publication of this announcement.

---

## **AAMI (Association for the Advancement of Medical Instrumentation)**

901 N. Glebe Road, Suite 300, Arlington, VA 22203 [www.aami.org](http://www.aami.org)

Contact: Cliff Bernier; [cbernier@aami.org](mailto:cbernier@aami.org)

### ***New National Adoption***

BSR/AAMI/ISO 18472-202x, Sterilization of health care products - Biological and chemical indicators - Test equipment (identical national adoption of ISO 18472:2018)

Stakeholders: Biological and chemical indicator manufacturers.

Project Need: Provides requirements for performance of test equipment (resistometers) for testing and characterizing biological and chemical indicators.

Scope: This document specifies the requirements for test equipment to be used to:

- test biological indicators for steam, ethylene oxide gas, and dry heat sterilization processes for conformity to the requirements given in ISO 11138 series;
- test chemical indicators for steam, ethylene oxide gas, dry heat and vaporized hydrogen peroxide sterilization processes for conformity to the requirements given in ISO 11140-1:2014.

This document also provides informative methods useful in characterizing the performance of biological and chemical indicators for intended use and for routine quality control testing.

## **ASHRAE (American Society of Heating, Refrigerating and Air-Conditioning Engineers, Inc.)**

1791 Tullie Circle NE, Atlanta, GA 30329 [www.ashrae.org](http://www.ashrae.org)

Contact: Tanisha Meyers-Lisle; [tmlisle@ashrae.org](mailto:tmlisle@ashrae.org)

### ***Revision***

BSR/ASHRAE Standard 209-202X, Energy Simulation Aided Design for Buildings Except Low-Rise Residential Buildings (revision of ANSI/ASHRAE Standard 209-2018)

Stakeholders: Building energy modelers, architects, and design engineers.

Project Need: To revise Standard 209 which is already referenced by AIA, USGBC, ASHRAE, IBPSA-USA, and others.

Scope: This standard applies to new buildings or major renovations of, or additions to, existing buildings utilizing energy simulation during the design process. This standard does not apply to single-family houses, multi-family structures of three stories or fewer above grade, manufactured houses (mobile homes) and modular homes.

**EOS/ESD (ESD Association, Inc.)**

7902 Turin Road, Building 3, Rome, NY 13440-2069 [www.esda.org](http://www.esda.org)

Contact: Lauren Roosevelt; [laurenradmin@esda.org](mailto:laurenradmin@esda.org)

**Revision**

BSR/ESD STM3.1-202x, ESD Association Standard Test Method for the Protection of Electrostatic Discharge Susceptible Items - Ionization (revision of ANSI/ESD STM3.1-2015)

Stakeholders: Electronics Industry including telecom, consumer, medical, and industrial

Project Need: This document provides test methods and procedures for evaluating and selecting air ionization equipment and systems (ionizers).

Scope: This standard test method establishes measurement techniques, under specified conditions, to determine offset voltage (ion balance) and discharge time (charge neutralization time) for ionizers. This standard test method does not include measurements of electromagnetic interference (EMI), or uses of ionizers in connection with ordnance, flammables, explosive items, or electrically initiated explosive devices.

**IAPMO (ASSE Chapter) (ASSE International Chapter of IAPMO)**

18927 Hickory Creek Drive, Suite 220, Mokena, IL 60448 [www.asse-plumbing.org](http://www.asse-plumbing.org)

Contact: Marianne Waickman; [marianne.waickman@asse-plumbing.org](mailto:marianne.waickman@asse-plumbing.org)

**New Standard**

BSR/ASSE Series 27000-202x, Professional Qualification Standard for the Design, Installation, Inspection, Testing and Maintenance of Hybrid Fire Extinguishing Systems (new standard)

Stakeholders: Owners and occupants of commercial and industrial facilities that use these special hazard fire protection systems. Fire protection system designers and inspectors. Sprinkler fitters, fire-protection professionals, fire marshals, and municipalities.

Project Need: There is not currently a standard that covers the personnel who work on NFPA 770 systems.

Scope: This standard fills a requirement that is part of NFPA 770. NFPA 770 requires certification for designers, installers and ITM personnel (inspection, testing, and maintenance) who work on systems as described in NFPA 770. These are special hazard fire protection systems that use hybrid (water and inert gas) fire extinguishing systems.

**IAPMO (ASSE Chapter) (ASSE International Chapter of IAPMO)**

18927 Hickory Creek Drive, Suite 220, Mokena, IL 60448 [www.asse-plumbing.org](http://www.asse-plumbing.org)

Contact: Terry Burger; [terry.burger@asse-plumbing.org](mailto:terry.burger@asse-plumbing.org)

**New Standard**

BSR/ASSE 1105-202x, Automatic Hot Water Balancing Valve (new standard)

Stakeholders: Plumbing, construction.

Project Need: There currently are not any standards covering this type of product.

Scope: The scope of this standard covers automatic hot-water balancing valves used in potable water systems. It covers performance, testing, and labeling requirements. The automatic hot-water balancing valve includes thermostatic (fixed-cartridge or adjustable type), pressure-independent (fixed-cartridge or adjustable type), and electronically actuated type. Automatic hot-water balancing valve control thermal losses in the potable hot-water distribution system to maintain the design temperature.

**IEEE (ASC C63) (Institute of Electrical and Electronics Engineers)**

445 Hoes Lane, Piscataway, NJ 08854 [www.ieee.org](http://www.ieee.org)

Contact: Jennifer Santulli; [J.Santulli@ieee.org](mailto:J.Santulli@ieee.org)

**Revision**

BSR C63.2-202x, Standard for Specifications of Electromagnetic Interference and Field Strength Measuring Instrumentation in the Frequency Range 9 kHz to 40 GHz (revision of ANSI C63.2-2016)

Stakeholders: All users of the ANSI C63.4, C63.10, and C63.26 standards, including test labs, radio manufacturers, electronics manufacturers, test equipment manufacturers, regulators and accreditation bodies.

Project Need: CISPR 16-1-1:2010 is a key reference document for ANSI C63.2. CISPR 16-1-1:2010 has been updated twice since 2010 Ed. 3.2: 2014 reference (Ed. 4: 2015 and Ed.5: 2019). This proposal recommends updating the CISPR 16-1-1 reference in ANSI C63.2 to CISPR 16-1-1:2019 (Ed. 5). Also, CISPR 16-1-1:2019 reorganized several sections and added material from ANSI C63.2-2016. This reorganization and the added parameter would need to be accounted for in C63.2-2016 Tables 1 and 2. Members of the EMI test community that reference C63.2 when purchasing equipment will question the reference to an obsolete CISPR document and there is increasing risk of divergence of receiver requirements between CISPR and ANSI.

Scope: C63.2 specifies measurement equipment requirements for ANSI emissions measurement documents

**ITI (INCITS) (InterNational Committee for Information Technology Standards)**

700 K Street NW, Suite 600, Washington, DC 20001 [www.incits.org](http://www.incits.org)

Contact: Deborah Spittle; [comments@standards.incits.org](mailto:comments@standards.incits.org)

**New National Adoption**

INCITS/ISO/IEC 7812-1:2017 [202x], Identification Cards - Identification of Issuers - Part 1: Numbering System (identical national adoption of ISO/IEC 7812-1:2017 and revision of INCITS/ISO/IEC 7812-1:2015 [2016])

Stakeholders: ICT industry.

Project Need: Adoption of this International standard is beneficial to the ICT industry.

Scope: Specifies a numbering system for the identification of the card issuers, the format of the issuer identification number (IIN) and the primary account number (PAN).

**ITI (INCITS) (InterNational Committee for Information Technology Standards)**

700 K Street NW, Suite 600, Washington, DC 20001 [www.incits.org](http://www.incits.org)

Contact: Deborah Spittle; [comments@standards.incits.org](mailto:comments@standards.incits.org)

**New National Adoption**

INCITS/ISO/IEC 7816-4:2020 [202x], Identification Cards - Integrated Circuit Cards - Part 4: Organization, Security and Commands for Interchange (identical national adoption of ISO/IEC 7816-4:2020 and revision of INCITS/ISO/IEC 7816-4:2013 [2016])

Stakeholders: ICT industry.

Project Need: Adoption of this International standard is beneficial to the ICT industry.

Scope: Is intended to be used in any sector of activity. It specifies: (a) contents of command-response pairs exchanged at the interface, (b) means of retrieval of data elements and data objects in the card, (c) structures and contents of historical bytes to describe operating characteristics of the card, (d) structures for applications and data in the card, as seen at the interface when processing commands, (e) access methods to files and data in the card, (f) a security architecture defining access rights to files and data in the card, (g) means and mechanisms for identifying and addressing applications in the card, (h) methods for secure messaging, and (i) access methods to the algorithms processed by the card. It does not describe these algorithms.

**ITI (INCITS) (InterNational Committee for Information Technology Standards)**

700 K Street NW, Suite 600, Washington, DC 20001 [www.incits.org](http://www.incits.org)

Contact: Deborah Spittle; [comments@standards.incits.org](mailto:comments@standards.incits.org)

***New National Adoption***

INCITS/ISO/IEC 10373-6:2020 [202x], Cards and security devices for personal identification - Test methods - Part 6: Contactless proximity objects (identical national adoption of ISO/IEC 10373-6:2020 and revision of INCITS/ISO/IEC 10373-6:2016 [2016])

Stakeholders: ICT industry.

Project Need: Adoption of this International standard is beneficial to the ICT industry.

Scope: Defines test methods for characteristics of identification cards according to the definition given in ISO/IEC 7810. Each test method is cross-referenced to one or more base standards, which can be ISO/IEC 7810 or one or more of the supplementary standards that define the information storage technologies employed in identification card applications.

**ITI (INCITS) (InterNational Committee for Information Technology Standards)**

700 K Street NW, Suite 600, Washington, DC 20001 [www.incits.org](http://www.incits.org)

Contact: Deborah Spittle; [comments@standards.incits.org](mailto:comments@standards.incits.org)

***New National Adoption***

INCITS/ISO/IEC 11695-3:2017 [202x], Identification Cards - Optical Memory Cards - Holographic Recording Method - Part 3: Optical Properties and Characteristics (identical national adoption of ISO/IEC 11695-3:2017 and revision of INCITS/ISO/IEC 11695-3:2008 [R2016])

Stakeholders: ICT industry.

Project Need: Adoption of this International standard is beneficial to the ICT industry.

Scope: Specifies the optical properties and characteristics of optical memory cards using the holographic recording method

**ITI (INCITS) (InterNational Committee for Information Technology Standards)**

700 K Street NW, Suite 600, Washington, DC 20001 [www.incits.org](http://www.incits.org)

Contact: Deborah Spittle; [comments@standards.incits.org](mailto:comments@standards.incits.org)

***New National Adoption***

INCITS/ISO/IEC 14443-2:2020 [202x], Cards and security devices for personal identification - Contactless proximity objects - Part 2: Radio frequency power and signal interface (identical national adoption of ISO/IEC 14443-2:2020 and revision of INCITS/ISO/IEC 14443-2:2016 [2016])

Stakeholders: ICT industry.

Project Need: Adoption of this International standard is beneficial to the ICT industry.

Scope: Specifies the characteristics of the fields to be provided for power and bi-directional communication between proximity coupling devices (PCDs) and proximity cards or objects (PICCs). This document does not specify the means of generating coupling fields, nor the means of compliance with electromagnetic radiation and human exposure regulations, which can vary depending on the country.

**ITI (INCITS) (InterNational Committee for Information Technology Standards)**

700 K Street NW, Suite 600, Washington, DC 20001 [www.incits.org](http://www.incits.org)

Contact: Deborah Spittle; [comments@standards.incits.org](mailto:comments@standards.incits.org)

***New National Adoption***

INCITS/ISO/IEC 18013-2:2020 [202x], Personal identification - ISO-compliant driving licence - Part 2: Machine-readable technologies (identical national adoption of ISO/IEC 18013-2:2020 and revision of INCITS/ISO/IEC 18013-2:2008 [R2016])

Stakeholders: ICT industry.

Project Need: Adoption of this International standard is beneficial to the ICT industry.

Scope: The purpose of storing IDL data on machine-readable media on the IDL is to: increase productivity (of data and IDL use), facilitate electronic data exchange, and assist in authenticity and integrity validation. This document thus specifies the following: mandatory and optional machine-readable data; the logical data structure; and encoding rules for the machine-readable technologies currently supported.

**ITI (INCITS) (InterNational Committee for Information Technology Standards)**

700 K Street NW, Suite 600, Washington, DC 20001 [www.incits.org](http://www.incits.org)

Contact: Deborah Spittle; [comments@standards.incits.org](mailto:comments@standards.incits.org)

***New National Adoption***

INCITS/ISO/IEC 19763-3:2020 [202x], Information Technology - Metamodel Framework for Interoperability (MFI) - Part 3: Metamodel for Ontology Registration (identical national adoption of ISO/IEC 19763-3:2020 and revision of INCITS/ISO/IEC 19763-3:2010 [R2016])

Stakeholders: ICT industry.

Project Need: Adoption of this International standard is beneficial to the ICT industry.

Scope: Specifies the metamodel that provides a facility to register administrative and evolution information related to ontologies. The metamodel is intended to promote interoperability among application systems, by providing administrative and evolution information related to ontologies, accompanied with standardized ontology repositories that register ontologies themselves in specific languages. This document does not specify the metamodels of ontologies expressed in specific languages and the mappings among them.

**ITI (INCITS) (InterNational Committee for Information Technology Standards)**

700 K Street NW, Suite 600, Washington, DC 20001 [www.incits.org](http://www.incits.org)

Contact: Deborah Spittle; [comments@standards.incits.org](mailto:comments@standards.incits.org)

***New National Adoption***

INCITS/ISO/IEC 23000-6:2012 [202x], Information technology - Multimedia application format (MPEG-A) - Part 6: Professional archival application format (identical national adoption of ISO/IEC 23000-6:2012 and revision of INCITS/ISO/IEC 23000-6:2009 [R2016])

Stakeholders: ICT industry.

Project Need: Adoption of this International standard is beneficial to the ICT industry.

Scope: The purpose of the PA-AF is to provide a standardized packaging format for digital files. This packaging format can also serve as an implementation of the information package specified by the Reference Model of Open Archival Information System (OAIS). The OAIS Reference Model is a framework for understanding and applying concepts necessary for long-term digital information preservation (where "long-term" is long enough to be concerned about changing technologies). In addition, PA-AF can also be used as an intermediate or exchange packaging format for any kind of multimedia content.

**ITI (INCITS) (InterNational Committee for Information Technology Standards)**

700 K Street NW, Suite 600, Washington, DC 20001 [www.incits.org](http://www.incits.org)

Contact: Deborah Spittle; [comments@standards.incits.org](mailto:comments@standards.incits.org)

***New National Adoption***

INCITS/ISO/IEC 23000-10:2012 [202x], Information technology - Multimedia application format (MPEG-A) - Part 10: Surveillance application format (identical national adoption of ISO/IEC 23000-10:2012 and revision of INCITS/ISO/IEC 23000-10:2009 [R2016])

Stakeholders: ICT industry.

Project Need: Adoption of this International standard is beneficial to the ICT industry.

Scope: Specifies a file format designed to store data in and exchange data between surveillance systems. The file format provides an overall structure for media content and associated metadata. Media data coverage includes image, video and audio data. Specific features to support application of the format in surveillance systems include dedicated time information in a separate track as well as segmentation and segment linking provisions for media data

# Call for Comment on Standards Proposals

## American National Standards

This section solicits public comments on proposed draft new American National Standards, including the national adoption of ISO and IEC standards as American National Standards, and on proposals to revise, reaffirm or withdraw approval of existing American National Standards. A draft standard is listed in this section under the ANSI-accredited standards developer (ASD) that sponsors it and from whom a copy may be obtained. Comments in connection with a draft American National Standard must be submitted in writing to the ASD no later than the last day of the comment period specified herein. Such comments shall be specific to the section(s) of the standard under review and include sufficient detail so as to enable the reader to understand the commenter's position, concerns and suggested alternative language, if appropriate. Please note that the ANSI Executive Standards Council (ExSC) has determined that an ASD has the right to require that interested parties submit public review comments electronically, in accordance with the developer's procedures.

### Ordering Instructions for "Call-for-Comment" Listings

1. Order from the organization indicated for the specific proposal.
2. Use the full identification in your order, including the BSR prefix; for example, Electric Fuses BSR/SAE J554.
3. Include remittance with all orders.
4. BSR proposals will not be available after the deadline of call for comment.

Comments should be addressed to the organization indicated, with a copy to the Board of Standards Review, American National Standards Institute, 25 West 43rd Street, New York, NY 10036. e-mail: [psa@ansi.org](mailto:psa@ansi.org)

\* Standard for consumer products

## Comment Deadline: March 14, 2021

### IIAR (International Institute of Ammonia Refrigeration)

1001 North Fairfax Street, Alexandria, VA 22314 p: (703) 312-4200 w: [www.iiar.org](http://www.iiar.org)

#### ***New Standard***

BSR/IIAR CO2-202X, Safety Standard for Closed-Circuit Carbon Dioxide Refrigeration Systems (new standard)

This standard specifies minimum requirements for the safe design; installation; startup; and inspection, testing, and maintenance (ITM) of closed-circuit carbon dioxide refrigeration systems and modifications or additions to an existing system.

[Click here to view these changes in full](#)

Send comments (with optional copy to [psa@ansi.org](mailto:psa@ansi.org)) to: Tony Lundell; [tony\\_lundell@iiar.org](mailto:tony_lundell@iiar.org)

### NSF (NSF International)

789 N. Dixboro Road, Ann Arbor, MI 48105-9723 p: (734) 827-6866 w: [www.nsf.org](http://www.nsf.org)

#### ***Revision***

BSR/NSF 455-2-202x (i10), Good Manufacturing Practices for Dietary Supplements (revision of ANSI/NSF 455-2-2020)

This Standard is intended to define a standardized approach for auditing to determine the level of compliance of dietary supplement products to 21 CFR 111 Current Good Manufacturing Practices (GMPs) in Manufacturing, Packaging, Labeling, or Holding Operations for Dietary Supplements as well as incorporating additional retailer requirements. It refers to the requirements for GMP applicable to all dietary supplements. It will assist in the determination of adequate facilities and controls for dietary supplement manufacture with sufficient quality to ensure suitability for intended use.

[Click here to view these changes in full](#)

Send comments (with optional copy to [psa@ansi.org](mailto:psa@ansi.org)) to: Rachel Brooker; [rbrooker@nsf.org](mailto:rbrooker@nsf.org)



## Comment Deadline: March 14, 2021

### SPRI (Single Ply Roofing Industry)

465 Waverley Oaks Road, Suite 421, Waltham, MA 02452 p: (781) 647-7026 w: [www.spri.org](http://www.spri.org)

#### ***New Standard***

BSR/SPRI/FM BPT-1-202x, Test Standard for Comparative Pull-Through Strengths of Insulation Fastening Systems and Substrate Board Materials Used with Low Slope Roofing Systems (new standard)

This standard will allow the roofing industry to perform comparative small-scale testing of roofing fasteners and/or stress plates through board stock materials, such as insulations, cover boards, etc. This standard provides basic requirements and procedures for determining the maximum failure load of substrate boards, fasteners, or fastening systems when tested for dynamic pull-through resistance.

[Click here to view these changes in full](#)

Send comments (with optional copy to [psa@ansi.org](mailto:psa@ansi.org)) to: Linda King; [info@spri.org](mailto:info@spri.org)

### UL (Underwriters Laboratories)

333 Pfingsten Road, Northbrook, IL 60062-2096 p: (847) 664-2850 w: <https://ul.org/>

#### ***Revision***

BSR/UL 508A-202x, Standard for Safety for Industrial Control Panels (revision of ANSI/UL 508A-2020)

Withdrawal of balloted proposal: (8) - Current Limiting Reactor (CLR).

[Click here to view these changes in full](#)

Send comments (with optional copy to [psa@ansi.org](mailto:psa@ansi.org)) to: Follow the instructions in the following website to enter comments into the CSDS Work Area: <https://csds.ul.com/Home/ProposalsDefault.aspx>

### UL (Underwriters Laboratories)

12 Laboratory Drive, Research Triangle Park, NC 27709-3995 p: (919) 549-1392 w: <https://ul.org/>

#### ***Revision***

BSR/UL 2367-202X, Standard for Safety for Solid State Overcurrent Protectors (revision of ANSI/UL 2367-2009 (R2018))

This recirculation proposal provides revisions to the UL 2367 proposal dated 11-06-20.

[Click here to view these changes in full](#)

Send comments (with optional copy to [psa@ansi.org](mailto:psa@ansi.org)) to: Follow the instructions in the following website to enter comments into the CSDS Work Area: <https://csds.ul.com/Home/ProposalsDefault.aspx>

### UL (Underwriters Laboratories)

333 Pfingsten Road, Northbrook, IL 60062-2096 p: (847) 664-1725 w: <https://ul.org/>

#### ***Revision***

BSR/UL 6703-202x, Standard for Safety for Connectors for Use in Photovoltaic Systems (revision of ANSI/UL 6703-2020)

This proposal for UL 6703 covers: (1) Align the voltage rating for both single-pole and multi-pole PV connectors.

[Click here to view these changes in full](#)

Send comments (with optional copy to [psa@ansi.org](mailto:psa@ansi.org)) to: Follow the instructions in the following website to enter comments into the CSDS Work Area: <https://csds.ul.com/Home/ProposalsDefault.aspx>

## Comment Deadline: March 29, 2021

### **AAFS (American Academy of Forensic Sciences)**

410 North 21st Street, Colorado Springs, CO 80904 p: (719) 453-1036 w: [www.aafs.org](http://www.aafs.org)

#### ***New Standard***

BSR/ASB Std 092-202x, Standard for Training and Certification of Canine Detection of Explosives (new standard)

This standard provides the training requirements for a canine team (canine handler and canine), and details follow-on assessments for trained canine teams, in the field of explosives detection including traditional explosives detection canines (EDC), person screening canines (PSC), and explosives detection canines with person screening capabilities (EDC w/PSC). This standard is intended to be used as the basis for all phases of the training process and includes certification procedures, training and assessments, record keeping, and document management.

(Please note that comments on a re-circulation will only be accepted on revised sections of a document, comments made to text not revised from the original public comment period will not be accepted.)

Single copy price: Free

Obtain an electronic copy from: Updated redline version, and comments: <http://www.asbstandardsboard.org/notice-of-standard-development-and-coordination/>.

Order from: [www.asbstandardsboard.org](http://www.asbstandardsboard.org)

Send comments (with optional copy to [psa@ansi.org](mailto:psa@ansi.org)) to: [asb@aafs.org](mailto:asb@aafs.org)

### **APTech (ASC CGATS) (Association for Print Technologies)**

1896 Preston White Drive, Reston, VA 20191 p: (703) 264-7200 w: [www.printtechnologies.org](http://www.printtechnologies.org)

#### ***Reaffirmation***

BSR CGATS/ISO 12640-1-2007 (R202x), Graphic technology - Prepress digital data exchange - Part 1: CMYK standard colour image data (CMYK/SCID) (reaffirmation of ANSI CGATS/ISO 12640-1-2007 (R2015))

This standard specifies the CMYK digital data that represents a set of standard color images to be used for evaluation of changes in image quality during coding, image processing (including transformation, compression and decompression), film recording or printing which can be used for research, development, product evaluation, and process control.

Single copy price: \$80.00

Obtain an electronic copy from: [dorf@aptech.org](mailto:dorf@aptech.org)

Order from: Debra Orf; [dorf@aptech.org](mailto:dorf@aptech.org)

Send comments (with optional copy to [psa@ansi.org](mailto:psa@ansi.org)) to: Same

### **APTech (ASC CGATS) (Association for Print Technologies)**

1896 Preston White Drive, Reston, VA 20191 p: (703) 264-7200 w: [www.printtechnologies.org](http://www.printtechnologies.org)

#### ***Reaffirmation***

BSR CGATS/ISO 12640-2-2007 (R202x), Graphic Technology - Prepress Digital Data Exchange - Part 2: XYZ/SRGB Encoded Standard Colour Image Data (XYZ/SCID) (reaffirm a national adoption ANSI CGATS/ISO 12640-2-2007 (R2013))

This part of ISO 12640 specifies a set of 15 standard color images (encoded as both 16-bit XYZ and 8-bit RGB digital data provided in electronic data files) that can be used for the evaluation of changes in image quality during coding, image processing (including transformation compression and decompression), displaying on a colour monitor or printing. They can be used for many graphic technology applications such as research, development, product evaluation, and process control.

Single copy price: \$80.00

Obtain an electronic copy from: [dorf@aptech.org](mailto:dorf@aptech.org)

Order from: Debra Orf; [dorf@aptech.org](mailto:dorf@aptech.org)

Send comments (with optional copy to [psa@ansi.org](mailto:psa@ansi.org)) to: Same

## Comment Deadline: March 29, 2021

### **APTech (ASC CGATS) (Association for Print Technologies)**

1896 Preston White Drive, Reston, VA 20191 p: (703) 264-7200 w: [www.printtechnologies.org](http://www.printtechnologies.org)

#### ***Withdrawal***

ANSI CGATS.7-2003 (R2013), Graphic technology - Pallet loading for printed materials (withdrawal of ANSI CGATS.7-2003 (R2013))

This standard specifies the stacking, unitizing, protection, and labeling of palletized printed materials. It also specifies the functional design of pallets used to transport printed materials and gives specifications for their loading onto delivery vehicles.

Single copy price: \$16.00

Obtain an electronic copy from: [dorf@aptech.org](mailto:dorf@aptech.org)

Order from: Debra Orf; [dorf@aptech.org](mailto:dorf@aptech.org)

Send comments (with optional copy to [psa@ansi.org](mailto:psa@ansi.org)) to: Same

### **ASHRAE (American Society of Heating, Refrigerating and Air-Conditioning Engineers, Inc.)**

1791 Tullie Circle NE, Atlanta, GA 30329 p: (678) 539-1111 w: [www.ashrae.org](http://www.ashrae.org)

#### ***Reaffirmation***

BSR/ASHRAE Standard 203-2018 (R202x), Method of Test for Determining Heat Gain of Office Equipment Used in Buildings (reaffirmation of ANSI/ASHRAE Standard 203-2018)

This standard prescribes methods of test to determine the range and average operating heat gains of electrical equipment for use in cooling load calculations.

Single copy price: \$35.00

Obtain an electronic copy from: Free download at <http://www.ashrae.org/standards-research--technology/public-review-drafts>

Order from: Send request to [standards.section@ashrae.org](mailto:standards.section@ashrae.org)

Send comments (with optional copy to [psa@ansi.org](mailto:psa@ansi.org)) to: Online Comment Database at <http://www.ashrae.org/standards-research--technology/public-review-drafts>

### **AWS (American Welding Society)**

8669 NW 36th Street, Suite 130, Miami, FL 33166-6672 p: (305) 443-9353 334 w: [www.aws.org](http://www.aws.org)

#### ***Revision***

BSR/AWS G2.4/G2.4M-202x, Guide for the Fusion Welding of Titanium and Titanium Alloys (revision of ANSI/AWS G2.4/G2.4M-2014)

The Guide for the Fusion Welding of Titanium and Titanium Alloys provides instructional guidance for the welding of titanium and titanium alloys. This guide explains processes, equipment, materials, workshop practices, joint preparation, welding technique, tests, and the repair of discontinuities.

Single copy price: \$38.00

Obtain an electronic copy from: [sborrero@aws.org](mailto:sborrero@aws.org)

Order from: Stephen Borrero; [sborrero@aws.org](mailto:sborrero@aws.org)

Send comments (with optional copy to [psa@ansi.org](mailto:psa@ansi.org)) to: Same

### **AWWA (American Water Works Association)**

6666 W. Quincy Avenue, Denver, CO 80235 p: (303) 347-6178 w: [www.awwa.org](http://www.awwa.org)

#### ***Revision***

BSR/AWWA C671-202x, Online Turbidimeter Operation and Maintenance (revision of ANSI/AWWA C671-2015)

This standard describes online turbidimeter operation and maintenance (O&M) for online turbidimeters used in the treatment and monitoring of potable water, reclaimed water, or wastewater effluent.

Single copy price: Free

Obtain an electronic copy from: [ETSSupport@awwa.org](mailto:ETSSupport@awwa.org)

Order from: AWWA, Attn: Vicki David; [vdavid@awwa.org](mailto:vdavid@awwa.org)

Send comments (with optional copy to [psa@ansi.org](mailto:psa@ansi.org)) to: AWWA, Attn: Paul J. Olson; [polson@awwa.org](mailto:polson@awwa.org)

## Comment Deadline: March 29, 2021

### EOS/ESD (ESD Association, Inc.)

7902 Turin Road, Building 3, Rome, NY 13440-2069 p: (315) 339-6937 w: [www.esda.org](http://www.esda.org)

#### Revision

BSR/ESD S8.1-202x, ESD Association Standard for Protection of Electrostatic Discharge Susceptible Items - Symbols - ESD Awareness (revision of ANSI/ESD S8.1-2017)

This document covers the ESD susceptibility, ESD protective, and ESD common point ground symbols. The application of these ESD symbols on products is at the discretion of the supplier and does not constitute or imply a specific level of product performance.

Single copy price: \$105.00 (List)/\$75.00 (EOS/ESD Members) [Hard Cover]; \$130.00 (List)/\$100.00 (EOS/ESD Members) [Soft Cover]

Obtain an electronic copy from: [cearl@esda.org](mailto:cearl@esda.org)

Order from: Christina Earl; [cearl@esda.org](mailto:cearl@esda.org)

Send comments (with optional copy to [psa@ansi.org](mailto:psa@ansi.org)) to: Same

### EOS/ESD (ESD Association, Inc.)

7902 Turin Road, Building 3, Rome, NY 13440-2069 p: (315) 339-6937 w: [www.esda.org](http://www.esda.org)

#### Revision

BSR/ESD STM11.13-202x, ESD Association Standard Test Method for the Protection of Electrostatic Discharge Susceptible Items - Two-Point Resistance Measurement (revision of ANSI/ESD STM11.13-2018)

This document is intended for measuring materials with a resistance of greater than or equal to  $1.0 \times 10^4$  ohms and less than  $1.0 \times 10^{11}$  ohms.

Single copy price: \$105.00 (List)/\$75.00 (EOS/ESD Members) [Hard Cover]; \$130.00 (List)/\$100.00 (EOS/ESD Members) [Soft Cover]

Obtain an electronic copy from: [cearl@esda.org](mailto:cearl@esda.org)

Order from: Christina Earl; [cearl@esda.org](mailto:cearl@esda.org)

Send comments (with optional copy to [psa@ansi.org](mailto:psa@ansi.org)) to: Same

### HPS (ASC N13) (Health Physics Society)

1313 Dolley Madison Blvd #402, McLean, VA 22101 p: (703) 790-1745 w: [www.hps.org](http://www.hps.org)

#### Revision

BSR N13.1-202x, Sampling and Monitoring Releases of Airborne Radioactive Substances from the Stacks and Ducts of Nuclear Facilities (revision of ANSI N13.1-2011)

This standard sets forth guidelines and performance-based criteria for the design and use of systems for sampling the releases of airborne radioactive substances from the ducts and stacks of nuclear facilities.

Single copy price: \$50.00

Obtain an electronic copy from: [nanjohns@verizon.net](mailto:nanjohns@verizon.net)

Order from: Nancy Johnson; [nanjohns@verizon.net](mailto:nanjohns@verizon.net)

Send comments (with optional copy to [psa@ansi.org](mailto:psa@ansi.org)) to: Same

### NSF (NSF International)

789 N. Dixboro Road, Ann Arbor, MI 48105-9723 p: (734) 418-6660 w: [www.nsf.org](http://www.nsf.org)

#### Withdrawal

BSR/NSF 240-202x (i4r1), Drainfield Trench Product Sizing for Gravity Dispersal Onsite Wastewater Treatment and Dispersal Systems (withdrawal of ANSI/NSF 240-2011 (R2017) (i2r1))

This wastewater standard provides a methodology to compare, assess, and document product sizing criteria for alternative or proprietary products with respect to conventional coarse aggregate used in onsite wastewater dispersal drainfields, based on comparative hydraulic performance.

Single copy price: Free

Order from: Jason Snider; [jsnider@nsf.org](mailto:jsnider@nsf.org)

Send comments (with optional copy to [psa@ansi.org](mailto:psa@ansi.org)) to: Same

## Comment Deadline: March 29, 2021

### **SCTE (Society of Cable Telecommunications Engineers)**

140 Philips Rd, Exton, PA 19341 p: (800) 542-5040 w: [www.scte.org](http://www.scte.org)

#### **Revision**

BSR/SCTE 186-202x, Product Physical, Environmental, Electrical, Sustainability, and Quality Requirements for Cable Telecommunications (revision of ANSI/SCTE 186-2016)

This specification defines product physical, environmental, electrical, and sustainability requirements during transportation, storage, operation, and disposal. The specification is limited to indoor shelf, frame, rack, and cabinet-level mission critical cable systems equipment. Facilities for which this specification generally applies are network data centers and cable headends. This specification also applies to unmanned or remotely monitored distribution hubs where hub location, construction, and HVAC capabilities can result in less tightly controlled ambient operating climates and longer duration environmental stresses. The specification does not address requirements for outside cable plant equipment.

Single copy price: \$50.00

Obtain an electronic copy from: [admin@standards.scte.org](mailto:admin@standards.scte.org)

Order from: Global Engineering Documents, (800) 854-7179, [www.global.ihs.com](http://www.global.ihs.com)

Send comments (with optional copy to [psa@ansi.org](mailto:psa@ansi.org)) to: [admin@standards.scte.org](mailto:admin@standards.scte.org)

### **UL (Underwriters Laboratories)**

333 Pfingsten Road, Northbrook, IL 60062 p: (847) 664-1292 w: <https://ul.org/>

#### **New Standard**

BSR/UL 3100-202x, Standard for Safety for Automated Mobile Platforms (AMPs) (new standard)

This proposal for UL covers: (1) The proposed first edition of the Standard for Automated Mobile Platforms (AMPs), ANSI/CAN/UL 3100, covers battery-operated mobile platforms with or without a payload. These devices are intended to be used indoors only or as outdoor use devices in a commercial or industrial environment. The device is battery powered using either lead acid batteries or lithium based batteries that, if rechargeable, are charged through a conductive system while either on board or off board the device.

Single copy price: Free

Obtain an electronic copy from: <https://csds.ul.com/Home/ProposalsDefault.aspx>

Order from: <http://www.shopulstandards.com>

Send comments (with optional copy to [psa@ansi.org](mailto:psa@ansi.org)) to: Follow the instructions in the following website to enter comments into the CSDS Work Area: <https://csds.ul.com/Home/ProposalsDefault.aspx>

### **UL (Underwriters Laboratories)**

12 Laboratory Drive, Research Triangle Park, NC 27709-3995 p: (919) 549-0973 w: <https://ul.org/>

#### **Reaffirmation**

BSR/UL 10C-2016 (R202x), Standard for Positive Pressure Fire Tests of Door Assemblies (reaffirmation of ANSI/UL 10C-2016)

UL proposes a reaffirmation to UL 10C.

Single copy price: Free

Obtain an electronic copy from: <https://csds.ul.com/Home/ProposalsDefault.aspx>

Order from: <http://www.shopulstandards.com>

Send comments (with optional copy to [psa@ansi.org](mailto:psa@ansi.org)) to: Follow the instructions in the following website to enter comments into the CSDS Work Area: <https://csds.ul.com/Home/ProposalsDefault.aspx>

## Comment Deadline: March 29, 2021

### UL (Underwriters Laboratories)

333 Pfingsten Road, Northbrook, IL 60062 p: (847) 664-1292 w: <https://ul.org/>

#### **Reaffirmation**

BSR/UL 60947-7-1-2017 (R202x), Standard for Safety for Low-Voltage Switchgear and Controlgear - Part 7-1: Ancillary Equipment - Terminal Blocks for Copper Conductors (reaffirmation of ANSI/UL 60947-7-1-2017)

This proposal for UL 60947-7-1 covers: (1) Reaffirmation and continuance of the fourth edition of the Standard for Low-Voltage Switchgear and Controlgear - Part 7-1: Ancillary Equipment - Terminal Blocks for Copper Conductors, UL 60947-7-1, as a standard.

Single copy price: Free

Obtain an electronic copy from: <https://csds.ul.com/Home/ProposalsDefault.aspx>

Order from: <http://www.shopulstandards.com>

Send comments (with optional copy to [psa@ansi.org](mailto:psa@ansi.org)) to: Follow the instructions in the following website to enter comments into the CSDS Work Area: <https://csds.ul.com/Home/ProposalsDefault.aspx>

### UL (Underwriters Laboratories)

333 Pfingsten Road, Northbrook, IL 60062 p: (847) 664-1292 w: <https://ul.org/>

#### **Reaffirmation**

BSR/UL 60947-7-2-2017 (R202x), Standard for Safety for Low-Voltage Switchgear and Controlgear - Part 7-2: Ancillary Equipment - Protective Conductor Terminal Blocks for Copper Conductors (reaffirmation of ANSI/UL 60947-7-2-2017)

This proposal for UL 60947-7-2 covers: (1) Reaffirmation and continuance of the fourth edition of the Standard for Low-Voltage Switchgear and Controlgear - Part 7-2: Ancillary Equipment - Protective Conductor Terminal Blocks for Copper Conductors, UL 60947-7-2, as a standard.

Single copy price: Free

Obtain an electronic copy from: <https://csds.ul.com/Home/ProposalsDefault.aspx>

Order from: <http://www.shopulstandards.com>

Send comments (with optional copy to [psa@ansi.org](mailto:psa@ansi.org)) to: Follow the instructions in the following website to enter comments into the CSDS Work Area: <https://csds.ul.com/Home/ProposalsDefault.aspx>

### UL (Underwriters Laboratories)

333 Pfingsten Road, Northbrook, IL 60062 p: (847) 664-1292 w: <https://ul.org/>

#### **Reaffirmation**

BSR/UL 60947-7-3-2017 (R202x), Standard for Safety for Low-Voltage Switchgear and Controlgear - Part 7-3: Ancillary Equipment - Safety Requirements for Fuse Terminal Blocks (reaffirmation of ANSI/UL 60947-7-3-2017)

This proposal for UL 60947-7-3 covers: (1) Reaffirmation and continuance of the third edition of the Standard for Low-Voltage Switchgear and Controlgear - Part 7-3: Ancillary Equipment - Safety Requirements for Fuse Terminal Blocks, UL 60947-7-3, as a standard.

Single copy price: Free

Obtain an electronic copy from: <https://csds.ul.com/Home/ProposalsDefault.aspx>

Order from: <http://www.shopulstandards.com>

Send comments (with optional copy to [psa@ansi.org](mailto:psa@ansi.org)) to: Follow the instructions in the following website to enter comments into the CSDS Work Area: <https://csds.ul.com/Home/ProposalsDefault.aspx>

### UL (Underwriters Laboratories)

12 Laboratory Drive, Research Triangle Park, NC 27709-3995 p: (919) 549-0973 w: <https://ul.org/>

#### **Revision**

BSR/UL 1191-202X, Standard for Components for Personal Flotation Devices (revision of ANSI/UL 1191-2019)

UL proposes a recirculation to the UL 1191 proposals dated January 31, 2020 and June 26, 2020.

Single copy price: Free

Obtain an electronic copy from: <https://csds.ul.com/Home/ProposalsDefault.aspx>

Order from: <http://www.shopulstandards.com>

Send comments (with optional copy to [psa@ansi.org](mailto:psa@ansi.org)) to: Follow the instructions in the following website to enter comments into the CSDS Work Area: <https://csds.ul.com/Home/ProposalsDefault.aspx>

## Comment Deadline: April 13, 2021

### CGA (Compressed Gas Association)

8484 Westpark Drive, Suite 220, McLean, VA 22102 p: (703) 788-2728 w: [www.cganet.com](http://www.cganet.com)

#### Revision

Reaffirmations and withdrawals available electronically may be accessed at: [webstore.ansi.org](http://webstore.ansi.org)

BSR/CGA M-1-202x, Standard for Medical Gas Supply Systems at Health Care Facilities (revision of ANSI/CGA M-1-2018)

This standard provides the minimum requirements for the design, installation, maintenance, testing, and removal of compressed medical gases (CMG) supply systems at health care facilities. This standard applies to all new or upgraded CMG supply systems at health care facilities. This standard captures the requirements from relevant national regulations and model codes along with best practices to provide a comprehensive publication for the process of designing, locating, installing, commissioning, maintaining, testing, removing, and documenting work on a medical gas supply system.

Single copy price: Free

Obtain an electronic copy from: [kmastromichalis@cganet.com](mailto:kmastromichalis@cganet.com)

Order from: Kristy Mastromichalis; [kmastromichalis@cganet.com](mailto:kmastromichalis@cganet.com)

Send comments (with optional copy to [psa@ansi.org](mailto:psa@ansi.org)) to: Same

## Project Withdrawn

In accordance with clause 4.2.1.3.3 Discontinuance of a standards project of the ANSI Essential Requirements, an accredited standards developer may abandon the processing of a proposed new or revised American National Standard or portion thereof if it has followed its accredited procedures. The following projects have been withdrawn accordingly:

### API (American Petroleum Institute)

200 Massachusetts Avenue NW, Washington, DC 20001 p: (202) 682-8130 w: [www.api.org](http://www.api.org)

BSR/API MPMS Ch. 14.3 Part 4/AGA Report No. 3 Part 4/GPA 8185 Part 4, 4th Edition-200x, Background, Development, Implementation Procedures and Subroutine Documentation (new standard)

Describes the background and development of the equation for the coefficient of discharge of flange-tapped square-edged concentric orifice meters and recommends a flow rate of calculation procedure.

Inquiries may be directed to Sally Goodson; [goodsons@api.org](mailto:goodsons@api.org)

### API (American Petroleum Institute)

200 Massachusetts Avenue NW, Washington, DC 20001 p: (202) 682-8190 w: [www.api.org](http://www.api.org)

BSR/API Standard 613-2002 (R201x), Special Purpose Gear Units for Petroleum, Chemical, and Gas Industry Services (reaffirmation and redesignation of ANSI/API 613-2002 (R2010))

This standard covers the minimum requirements for special-purpose, enclosed, precision single- and double-helical one- and two-stage speed increasers and reducers of parallel shaft design for petroleum, chemical, and gas industry services. This standard is primarily intended for gear units that are in continuous service without installed spare equipment. Gear sets furnished to this standard shall be considered matched sets.

Inquiries may be directed to Duane Brown; [brownd@api.org](mailto:brownd@api.org)

### API (American Petroleum Institute)

200 Massachusetts Avenue NW, Washington, DC 20001 p: (202) 682-8507 w: [www.api.org](http://www.api.org)

BSR/API Spec 19G2/ISO 17078-2-200x, Specification for flow-control devices for side-pocket mandrels (identical national adoption of ISO 17078-2)

Inquiries may be directed to Katie Burkle; [burkle@api.org](mailto:burkle@api.org)

## Project Withdrawn

### **ASTM (ASTM International)**

100 Barr Harbor Drive, West Conshohocken, PA 19428-2959 p: (610) 832-9744 w: [www.astm.org](http://www.astm.org)

BSR/ASTM F628-202x, Specification for Acrylonitrile-Butadiene-Styrene (ABS) Schedule 40 Plastic Drain, Waste, and Vent Pipe with a Cellular Core (revision of ANSI/ASTM F628-2018)

Inquiries may be directed to Corice Leonard; [accreditation@astm.org](mailto:accreditation@astm.org)

### **ASTM (ASTM International)**

100 Barr Harbor Drive, West Conshohocken, PA 19428-2959 p: (610) 832-9744 w: [www.astm.org](http://www.astm.org)

BSR/ASTM F1273-1997 (R202x), Specification for Tank Vent Flame Arresters (reaffirmation of ANSI/ASTM F1273-1997 (R2013))

Inquiries may be directed to Corice Leonard; [accreditation@astm.org](mailto:accreditation@astm.org)

### **ASTM (ASTM International)**

100 Barr Harbor Drive, West Conshohocken, PA 19428-2959 p: (610) 832-9744 w: [www.astm.org](http://www.astm.org)

BSR/ASTM F2389-202x, Specification for Pressure-Rated Polypropylene (PP) Piping Systems (revision of ANSI/ASTM F2389-2019)

Inquiries may be directed to Corice Leonard; [accreditation@astm.org](mailto:accreditation@astm.org)

### **ASTM (ASTM International)**

100 Barr Harbor Drive, West Conshohocken, PA 19428-2959 p: (610) 832-9744 w: [www.astm.org](http://www.astm.org)

BSR/ASTM WK60578-202x, Test Method for Walkway Friction Testing using Portable Walkway Tribometers (new standard)

Inquiries may be directed to Corice Leonard; [accreditation@astm.org](mailto:accreditation@astm.org)

### **ASTM (ASTM International)**

100 Barr Harbor Drive, West Conshohocken, PA 19428-2959 p: (610) 832-9744 w: [www.astm.org](http://www.astm.org)

BSR/ASTM WK74677-202x, Specification for Polyethylene of Raised Temperature/Aluminum/Polyethylene of Raised Temperature (PERT/AL/PE-RT) Composite Pressure Pipe 1 based on Inner Diameter (ID) for Use in Air Conditioning and Refrigeration Line (new standard)

Inquiries may be directed to Corice Leonard; [accreditation@astm.org](mailto:accreditation@astm.org)

### **IAPMO (Z) (International Association of Plumbing & Mechanical Officials)**

4755 E. Philadelphia Street, Ontario, CA 91761-2816 p: (909) 218-8125 w: <https://www.iapmostandards.org>

BSR/IAPMO Z1226-202x, Drinking Water Fountains with or without Chiller or Heater (new standard)

Inquiries may be directed to Angela Juarez; [angela.juarez@iapmo.org](mailto:angela.juarez@iapmo.org)

## Withdrawal of an ANS by ANSI-Accredited Standards Developer

In accordance with clause 4.2.1.3.2 Withdrawal by ANSI-Accredited Standards Developer of the ANSI Essential Requirements, the following American National Standards have been withdrawn as an ANS.

### **API (American Petroleum Institute)**

200 Massachusetts Avenue NW, Washington, DC 20001 p: (202) 682-8190 w: [www.api.org](http://www.api.org)

ANSI/API 613-2002 (R2010), Special Purpose Gear Units for Petroleum, Chemical, and Gas Industry Services

Questions may be directed to: Duane Brown; [brownd@api.org](mailto:brownd@api.org)



## Withdrawal of an ANS by ANSI-Accredited Standards Developer

In accordance with clause 4.2.1.3.2 Withdrawal by ANSI-Accredited Standards Developer of the ANSI Essential Requirements, the following American National Standards have been withdrawn as an ANS.

### **API (American Petroleum Institute)**

200 Massachusetts Avenue NW, Washington, DC 20001 p: (202) 682-8130 w: [www.api.org](http://www.api.org)

ANSI/API MPMS Chapter 22.1, 2nd Edition-2015, General Guidelines for Developing Testing Protocols for Devices Used in the Measurement of Hydrocarbon Fluids

Questions may be directed to: Sally Goodson; [goodsons@api.org](mailto:goodsons@api.org)

In accordance with clause 4.2.1.3.2 Withdrawal by ANSI-Accredited Standards Developer of the ANSI Essential Requirements, the following American National Standards have been withdrawn as an ANS.

### **API (American Petroleum Institute)**

200 Massachusetts Avenue NW, Washington, DC 20001 p: (202) 682-8130 w: [www.api.org](http://www.api.org)

ANSI/API MPMS Chapter 22.3, 1st Edition-2015, Flare Gas Meters

Questions may be directed to: Sally Goodson; [goodsons@api.org](mailto:goodsons@api.org)

In accordance with clause 4.2.1.3.2 Withdrawal by ANSI-Accredited Standards Developer of the ANSI Essential Requirements, the following American National Standards have been withdrawn as an ANS.

### **API (American Petroleum Institute)**

200 Massachusetts Avenue NW, Washington, DC 20001 p: (202) 682-8507 w: [www.api.org](http://www.api.org)

ANSI/API Specification 19G1-2010, Side-Pocket Mandrels

Questions may be directed to: Katie Burkle; [burkle@api.org](mailto:burkle@api.org)

In accordance with clause 4.2.1.3.2 Withdrawal by ANSI-Accredited Standards Developer of the ANSI Essential Requirements, the following American National Standards have been withdrawn as an ANS.

### **API (American Petroleum Institute)**

200 Massachusetts Avenue NW, Washington, DC 20001 p: (202) 682-8507 w: [www.api.org](http://www.api.org)

ANSI/API Spec 11D3/ISO 15136-2-2008, Specification for Progressing Cavity Pump Systems for Artificial Lift - Surface-drive Systems

Questions may be directed to: Katie Burkle; [burkle@api.org](mailto:burkle@api.org)

In accordance with clause 4.2.1.3.2 Withdrawal by ANSI-Accredited Standards Developer of the ANSI Essential Requirements, the following American National Standards have been withdrawn as an ANS.

### **API (American Petroleum Institute)**

200 Massachusetts Avenue NW, Washington, DC 20001 p: (202) 330-9306 w: [www.api.org](http://www.api.org)

ANSI/API Standard 662, Part 2-2011, Plate Heat Exchangers for General Refinery Services, Part 2 - Brazed Aluminum Plate-fin Heat Exchangers

Questions may be directed to: Jose Godoy; [godoyj@api.org](mailto:godoyj@api.org)

# Final Actions on American National Standards

The standards actions listed below have been approved by the ANSI Board of Standards Review (BSR) or by an ANSI-Audited Designator, as applicable.

---

## **ASIS (ASIS International)**

1625 Prince Street, Alexandria, VA 22314-2818 p: (703) 518-1439 w: [www.asisonline.org](http://www.asisonline.org)

### ***Revision***

ANSI/ASIS PAP-2021, Physical Asset Protection (revision and redesignation of ANSI/ASIS PAP.1-2012) Final Action Date: 2/2/2021

## **ASTM (ASTM International)**

100 Barr Harbor Drive, West Conshohocken, PA 19428-2959 p: (610) 832-9744 w: [www.astm.org](http://www.astm.org)

### ***Reaffirmation***

ANSI/ASTM D4756-2015 (R2021), Practice for Installation of Rigid Poly(Vinyl Chloride) (PVC) Siding and Soffit (reaffirmation of ANSI/ASTM D4756-2015) Final Action Date: 2/2/2021

### ***Reaffirmation***

ANSI/ASTM F1201-1988 (R2021), Specification for Fluid Conditioner Fittings in Piping Applications above 0F (reaffirmation of ANSI/ASTM F1201-1988 (R2016)) Final Action Date: 1/1/2021

### ***Reaffirmation***

ANSI/ASTM F1431-1992 (R2021), Specification for Water Trap for Diesel Exhaust (reaffirmation of ANSI/ASTM F1431-1992 (R2016)) Final Action Date: 1/1/2021

### ***Reaffirmation***

ANSI/ASTM F1508-1996 (R2021), Specification for Angle Style, Pressure Relief Valves for Steam, Gas, and Liquid Services (reaffirmation of ANSI/ASTM F1508-1996 (R2016)) Final Action Date: 1/1/2021

### ***Reaffirmation***

ANSI/ASTM F1792-1997 (R2021), Specification for Special Requirements for Valves Used in Gaseous Oxygen Service (reaffirmation of ANSI/ASTM F1792-1997 (R2016)) Final Action Date: 1/1/2021

### ***Reaffirmation***

ANSI/ASTM F1793-1997 (R2021), Specification for Automatic Shut-Off Valves (Also Known as Excess Flow Valves, EFV) for Air or Nitrogen Service (reaffirmation of ANSI/ASTM F1793-1997 (R2016)) Final Action Date: 1/1/2021

### ***Reaffirmation***

ANSI/ASTM F1794-1997 (R2021), Specification for Hand-Operated, Globe-Style Valves for Gas (Except Oxygen Gas) and Hydraulic Systems (reaffirmation of ANSI/ASTM F1794-1997 (R2016)) Final Action Date: 1/1/2021

### ***Reaffirmation***

ANSI/ASTM F1799-2009 (R2021), Guide for Shipboard Generated Waste Management Audits (reaffirmation of ANSI/ASTM F1799-1997 (R2015)) Final Action Date: 1/1/2021

### ***Withdrawal***

ANSI/ASTM F1179-1997 (R2014), Practice for Inspection Procedure for Use of Anaerobic Thread Locking Compounds with Studs (withdrawal of ANSI/ASTM F1179-1997 (R2014)) Final Action Date: 12/1/2020

**ATIS (Alliance for Telecommunications Industry Solutions)**

1200 G Street NW, Suite 500, Washington, DC 20005 p: (202) 628-6380 w: [www.atis.org](http://www.atis.org)

**Stabilized Maintenance**

ANSI/ATIS 0500019-2010 (S2021), Request for Assistance Interface (RFAI) Specification (stabilized maintenance of ANSI/ATIS 0500019-2010 (R2015)) Final Action Date: 2/5/2021

**Stabilized Maintenance**

ANSI/ATIS 1000044-2011 (S2021), ATIS Identity Management: Requirements and Use Case Standard (stabilized maintenance of ANSI/ATIS 1000044-2011 (R2016)) Final Action Date: 2/1/2021

**AWS (American Welding Society)**

8669 NW 36th Street, Suite 130, Miami, FL 33166-6672 p: (305) 443-9353 334 w: [www.aws.org](http://www.aws.org)

**New Standard**

ANSI/AWS D10.10/D10.10M-2021, Recommended Practices for Local Heating of Welds in Piping and Tubing (new standard) Final Action Date: 2/2/2021

**AWWA (American Water Works Association)**

6666 W. Quincy Avenue, Denver, CO 80235 p: (303) 347-6178 w: [www.awwa.org](http://www.awwa.org)

**Revision**

ANSI/AWWA C605-2021, Underground Installation of Poly(Vinyl Chloride) (PVC) and Molecularly Oriented Poly(Vinyl Chloride) (PVC0) Pressure Pipe and Fittings (revision of ANSI/AWWA C605-2013) Final Action Date: 2/5/2021

**BIFMA (Business and Institutional Furniture Manufacturers Association)**

678 Front Avenue NW, Grand Rapids, MI 49504 p: (616) 591-9798 w: [www.bifma.org](http://www.bifma.org)

**Revision**

ANSI/BIFMA X5.5-2021, Desk and Table Products (revision of ANSI/BIFMA X5.5-2014) Final Action Date: 2/8/2021

**CTA (Consumer Technology Association)**

1919 South Eads Street, Arlington, VA 22202 p: (703) 907-7697 w: [www.cta.tech](http://www.cta.tech)

**\* New Standard**

ANSI/CTA 2090-2021, The Use of Artificial Intelligence in Health Care: Trustworthiness (new standard) Final Action Date: 2/4/2021

**ISA (International Society of Automation)**

67 Alexander Drive, Research Triangle Park, NC 27709 p: (919) 990-9213 w: [www.isa.org](http://www.isa.org)

**Revision**

ANSI/ISA 84.91.01-2021, Identification and Mechanical Integrity of Process Safety Controls, Alarms, and Interlocks in the Process Industry Sector (revision of ANSI/ISA 84.91.01-2012) Final Action Date: 2/4/2021

**LIA (ASC Z136) (Laser Institute of America)**

12001 Research Parkway, Suite 210, Orlando, FL 32828 p: (407) 380-1553 w: [www.laserinstitute.org](http://www.laserinstitute.org)

***New Standard***

ANSI Z136.4-2021, Standard Recommended Practice for Laser Safety Measurements for Classification and Hazard Evaluation (new standard) Final Action Date: 2/4/2021

**NEMA (ASC W1) (National Electrical Manufacturers Association)**

1300 North 17th Street, Rosslyn, VA 22209 p: (703) 841-3278 w: [www.nema.org](http://www.nema.org)

***New National Adoption***

ANSI/NEMA/IEC 60974-5-2021, Arc welding equipment - Part 5: Wire feeders (national adoption of with modifications and revision of ANSI/NEMA/IEC 60974-5-2008) Final Action Date: 2/2/2021

**NENA (National Emergency Number Association)**

1700 Diagonal Road, Suite 500, Alexandria, VA 22314 p: (727) 312-3230 w: [www.nena.org](http://www.nena.org)

***New Standard***

ANSI/NENA STA-011.1-2021, NENA Standards for 9-1-1 Professional Education (new standard) Final Action Date: 2/4/2021

**NFPA (National Fire Protection Association)**

One Batterymarch Park, Quincy, MA 02269-9101 p: (617) 984-7248 w: [www.nfpa.org](http://www.nfpa.org)

***New Standard***

ANSI/NFPA 475-2022, Recommended Practice for Organizing, Managing, and Sustaining a Hazardous Materials/Weapons of Mass Destruction Response Program (new standard) Final Action Date: 1/30/2021

**NSF (NSF International)**

789 N. Dixboro Road, Ann Arbor, MI 48105-9723 p: (734) 827-3817 w: [www.nsf.org](http://www.nsf.org)

***Revision***

ANSI/NSF 6-2021 (i17r1), Dispensing Freezers (revision of ANSI/NSF 6-2018) Final Action Date: 2/1/2021

***Revision***

ANSI/NSF 8-2021 (i18r1), Commercial Powered Food Preparation Equipment (revision of ANSI/NSF 8-2018) Final Action Date: 2/1/2021

***Revision***

ANSI/NSF 25-2021 (i13r1), Vending Machines for Food and Beverages (revision of ANSI/NSF 25-2017) Final Action Date: 2/1/2021

***Revision***

ANSI/NSF 385-2021 (i6r1), Disinfection Mechanics (revision of ANSI/NSF 385-2019) Final Action Date: 2/2/2021

**SCTE (Society of Cable Telecommunications Engineers)**

140 Philips Rd, Exton, PA 19341 p: (800) 542-5040 w: [www.scte.org](http://www.scte.org)

***New Standard***

ANSI/SCTE 260-8-2020, DPoE Security and Certification Specification (new standard) Final Action Date: 2/1/2021

**UL (Underwriters Laboratories)**

12 Laboratory Drive, Research Triangle Park, NC 27709-3995 p: (919) 549-1007 w: <https://ul.org/>

***Revision***

ANSI/UL 588-2021, Standard for Safety for Seasonal and Holiday Decorative Products (revision of ANSI/UL 588-2018) Final Action Date: 2/4/2021

***Revision***

ANSI/UL 746A-2021, Standard for Safety for Polymeric Materials - Short Term Property Evaluations (revision of ANSI/UL 746A-2020) Final Action Date: 2/3/2021

***Revision***

ANSI/UL 1026-2021, Standard for Safety for Household Electric Cooking and Food Serving Appliances (revision of ANSI/UL 1026-2012) Final Action Date: 2/2/2021

***Revision***

ANSI/UL 1042-2021, Standard for Safety for Electric Baseboard Heating Equipment (revision of ANSI/UL 1042-2009) Final Action Date: 2/2/2021

***Revision***

ANSI/UL 2021-2021, Standard for Safety for Fixed and Location-Dedicated Electric Room Heaters (revision of ANSI/UL 2021-2015) Final Action Date: 2/2/2021

# Call for Members (ANS Consensus Bodies)

Directly and materially affected parties who are interested in participating as a member of an ANS consensus body for the standards listed below are requested to contact the sponsoring standards developer directly and in a timely manner.

---

## **AAMI (Association for the Advancement of Medical Instrumentation)**

901 N. Glebe Road, Suite 300, Arlington, VA 22203 p: (703) 253-8263 w: [www.aami.org](http://www.aami.org)  
Cliff Bernier; [cbernier@aami.org](mailto:cbernier@aami.org)

BSR/AAMI/ISO 18472-202x, Sterilization of health care products - Biological and chemical indicators - Test equipment (identical national adoption of ISO 18472:2018)

## **ASHRAE (American Society of Heating, Refrigerating and Air-Conditioning Engineers, Inc.)**

1791 Tullie Circle NE, Atlanta, GA 30329 p: (678) 539-1111 w: [www.ashrae.org](http://www.ashrae.org)  
Tanisha Meyers-Lisle; [tmlisle@ashrae.org](mailto:tmlisle@ashrae.org)

BSR/ASHRAE Standard 209-202X, Energy Simulation Aided Design for Buildings Except Low-Rise Residential Buildings (revision of ANSI/ASHRAE Standard 209-2018)

## **CGA (Compressed Gas Association)**

8484 Westpark Drive, Suite 220, McLean, VA 22102 p: (703) 788-2728 w: [www.cganet.com](http://www.cganet.com)  
Kristy Mastromichalis; [kmastromichalis@cganet.com](mailto:kmastromichalis@cganet.com)

BSR/CGA M-1-202x, Standard for Medical Gas Supply Systems at Health Care Facilities (revision of ANSI/CGA M-1-2018)

## **EOS/ESD (ESD Association, Inc.)**

7902 Turin Road, Building 3, Rome, NY 13440-2069 p: (315) 339-6937 w: [www.esda.org](http://www.esda.org)  
Lauren Roosevelt; [laurenradmin@esda.org](mailto:laurenradmin@esda.org)

BSR/ESD STM3.1-202x, ESD Association Standard Test Method for the Protection of Electrostatic Discharge Susceptible Items - Ionization (revision of ANSI/ESD STM3.1-2015)

BSR/ESD S8.1-202x, ESD Association Standard for Protection of Electrostatic Discharge Susceptible Items - Symbols - ESD Awareness (revision of ANSI/ESD S8.1-2017)

BSR/ESD STM11.13-202x, ESD Association Standard Test Method for the Protection of Electrostatic Discharge Susceptible Items - Two-Point Resistance Measurement (revision of ANSI/ESD STM11.13-2018)

## **ITI (INCITS) (InterNational Committee for Information Technology Standards)**

700 K Street NW, Suite 600, Washington, DC 20001 p: (202) 737-8888 w: [www.incits.org](http://www.incits.org)  
Deborah Spittle; [comments@standards.incits.org](mailto:comments@standards.incits.org)

INCITS/ISO/IEC 7812-1:2017 [202x], Identification Cards - Identification of Issuers - Part 1: Numbering System (identical national adoption of ISO/IEC 7812-1:2017 and revision of INCITS/ISO/IEC 7812-1:2015 [2016])

INCITS/ISO/IEC 7816-4:2020 [202x], Identification Cards - Integrated Circuit Cards - Part 4: Organization, Security and Commands for Interchange (identical national adoption of ISO/IEC 7816-4:2020 and revision of INCITS/ISO/IEC 7816-4:2013 [2016])

INCITS/ISO/IEC 10373-6:2020 [202x], Cards and security devices for personal identification - Test methods - Part 6: Contactless proximity objects (identical national adoption of ISO/IEC 10373-6:2020 and revision of INCITS/ISO/IEC 10373-6:2016 [2016])

**ITI (INCITS) (InterNational Committee for Information Technology Standards)**

700 K Street NW, Suite 600, Washington, DC 20001 p: (202) 737-8888 w: [www.incits.org](http://www.incits.org)

INCITS/ISO/IEC 11695-3:2017 [202x], Identification Cards - Optical Memory Cards - Holographic Recording Method - Part 3: Optical Properties And Characteristics (identical national adoption of ISO/IEC 11695-3:2017 and revision of INCITS/ISO/IEC 11695-3:2008 [R2016])

INCITS/ISO/IEC 14443-2:2020 [202x], Cards and security devices for personal identification - Contactless proximity objects - Part 2: Radio frequency power and signal interface (identical national adoption of ISO/IEC 14443-2:2020 and revision of INCITS/ISO/IEC 14443-2:2016 [2016])

INCITS/ISO/IEC 18013-2:2020 [202x], Personal identification - ISO-compliant driving licence - Part 2: Machine-readable technologies (identical national adoption of ISO/IEC 18013-2:2020 and revision of INCITS/ISO/IEC 18013-2:2008 [R2016])

INCITS/ISO/IEC 19763-3:2020 [202x], Information Technology - Metamodel Framework for Interoperability (MFI) - Part 3: Metamodel for Ontology Registration (identical national adoption of ISO/IEC 19763-3:2020 and revision of INCITS/ISO/IEC 19763-3:2010 [R2016])

INCITS/ISO/IEC 23000-6:2012 [202x], Information technology - Multimedia application format (MPEG-A) - Part 6: Professional archival application format (identical national adoption of ISO/IEC 23000-6:2012 and revision of INCITS/ISO/IEC 23000-6:2009 [R2016])

INCITS/ISO/IEC 23000-10:2012 [202x], Information technology - Multimedia application format (MPEG-A) - Part 10: Surveillance application format (identical national adoption of ISO/IEC 23000-10:2012 and revision of INCITS/ISO/IEC 23000-10:2009 [R2016])

**NSF (NSF International)**

789 N. Dixboro Road, Ann Arbor, MI 48105-9723 p: (734) 418-6660 w: [www.nsf.org](http://www.nsf.org)

Jason Snider; [jsnider@nsf.org](mailto:jsnider@nsf.org)

BSR/NSF 240-202x (i4r1), Drainfield Trench Product Sizing for Gravity Dispersal Onsite Wastewater Treatment and Dispersal Systems (withdrawal of ANSI/NSF 240-2011 (R2017) (i2r1))

# Call for Members (ANS Consensus Bodies)

---

Directly and materially affected parties who are interested in participating as a member of an ANS consensus body for the standards listed below are requested to contact the sponsoring standards developer directly and in a timely manner

## ANSI Accredited Standards Developer

### AAMI (Association for the Advancement of Medical Instrumentation)

AAMI ([www.aami.org](http://www.aami.org)) is actively seeking participation in the following standards development work and in the interest categories specified:

BSR/AAMI/ISO 5840-1-202x, Cardiovascular implants - Cardiac valve prostheses - Part 1: General requirements (identical national adoption of ISO 5840-1:2020 and revision of ANSI/AAMI/ISO 5840-1-2015).

US adoption of AAMI/ISO 5840-1-202x, Cardiovascular implants - Cardiac valve prostheses - Part 1: General requirements. Applicable to heart valve substitutes intended for implantation and provides general requirements. Subsequent parts of the ISO 5840 series provide specific requirements. Applicable to newly developed and modified heart valve substitutes and to the accessory devices, packaging, and labelling required for their implantation and for determining the appropriate size of the heart valve substitute to be implanted. Seeking industry, user, regulator and general interest participation.

BSR/AAMI/ISO 5840-2-202x, Cardiovascular implants - Cardiac valve prostheses - Part 2: Surgically implanted heart valve substitutes (identical national adoption of ISO 5840-2:2020 and revision of ANSI/AAMI/ISO 5840-2-2015).

US adoption of AAMI/ISO 5840-2-202x, Cardiovascular implants - Cardiac valve prostheses - Part 2: Surgically implanted heart valve substitutes. Applicable to heart valve substitutes intended for implantation in human hearts, generally requiring cardiopulmonary bypass and generally with direct visualization. Applicable to both newly developed and modified surgical heart valve substitutes and to the accessory devices, packaging, and labelling required for their implantation and for determining the appropriate size of the surgical heart valve substitute to be implanted. Seeking industry, user, regulator and general interest participation.

BSR/AAMI/ISO 5840-3-202x, Cardiovascular implants - Cardiac valve prostheses - Part 3: Heart valve substitutes implanted by transcatheter techniques (national adoption of ISO 5840-3:2020 with modifications and revision of ANSI/AAMI/ISO 5840-3-2012).

US adoption of AAMI/ISO 5840-3-202x, Cardiovascular implants - Cardiac valve prostheses - Part 3: Heart valve substitutes implanted by transcatheter techniques. Applicable to all devices intended for implantation as a transcatheter heart valve substitute. Applicable to transcatheter heart valve substitutes and to the accessory devices, packaging and labelling required for their implantation and for determining the appropriate size of heart valve substitute to be implanted. Seeking industry, user, regulator and general interest participation.

BSR/AAMI/ISO 25539-2-202x, Cardiovascular implants - Endovascular devices - Part 2: Vascular stents (identical national adoption of ISO 25539-2:2020, Cardiovascular implants - Endovascular devices - Part 2: Vascular stents, and revision of ANSI/AAMI/ISO 25539-2-2012).

US adoption of AAMI/ISO 25539-2-202x, Cardiovascular implants - Endovascular devices - Part 2: Vascular stents. Specifies requirements for the evaluation of stent systems (vascular stents and delivery systems) and requirements with respect to nomenclature, design attributes and information supplied by the manufacturer, based upon current medical knowledge. Guidance for the development of in vitro test methods is included. Seeking industry, user, regulator and general interest participation.



## Call for Members (ANS Consensus Bodies)

### ANSI Accredited Standards Developer

#### GBI (Green Building Initiative)

Interested parties should apply by **February 15, 2021**

GBI is soliciting for Consensus Body members for the development of a new standard on Existing Buildings. BSR/GBI 02-202x, Green Globes Assessment Protocol for Existing Buildings (new standard)

The standard will include criteria and practices for resource-efficient, healthy, resilient, and environmentally preferable renovations, operations, maintenance, and improvement of existing commercial buildings. Up to six areas of green building design will be included: ESG management, site, energy, water, materials, and indoor environmental quality. GBI is looking for members in the following interest categories: Producer, Users and General Interest. Interested parties should apply by February 15, 2021. For more information and to apply for the Consensus Body for Existing Buildings, please use the appropriate form located at <https://www.thegbi.org/ansi>. You can send completed applications to Emily Marx, Manager of Standards and Program Support, at [marx@thegbi.org](mailto:marx@thegbi.org).

GBI (Green Building Initiative)

Office: 7805 SW 40th Ave. #80010, Portland, OR 97219

Contact: Emily Marx, Manager of Standards and Program Support

Phone: (503) 274-0448 x103

Email: [marx@thegbi.org](mailto:marx@thegbi.org)

### ANSI Accredited Standards Developer

#### INCITS Executive Board – ANSI Accredited SDO and US TAG to ISO/IEC JTC 1, Information Technology

The InterNational Committee for Information Technology Standards (INCITS), an ANSI accredited SDO, is the forum of choice for information technology developers, producers and users for the creation and maintenance of formal de jure IT standards. INCITS' mission is to promote the effective use of Information and Communication Technology through standardization in a way that balances the interests of all stakeholders and increases the global competitiveness of the member organizations.

The INCITS Executive Board serves as the consensus body with oversight of its 40+ Technical Committees. Additionally, the INCITS Executive Board has the international leadership role as the US Technical Advisory Group (TAG) to ISO/IEC JTC 1, Information Technology.

Membership in the INCITS Executive Board is open to all directly and materially affected parties in accordance with INCITS membership rules. To find out more about participating on the INCITS Executive Board, contact Jennifer Garner at [jgarner@itic.org](mailto:jgarner@itic.org) or visit <http://www.incits.org/participation/membership-info> for more information.

Membership in all interest categories is always welcome; however, the INCITS Executive Board seeks to broaden its membership base in the following categories:

- Service Providers
- Users
- Standards Development Organizations and Consortia
- Academic Institutions

## **Call for Members (ANS Consensus Bodies)**

### **ANSI Accredited Standards Developer**

#### **SCTE (Society of Cable Telecommunications Engineers)**

SCTE, an ANSI-accredited SDO, is the primary organization for the creation and maintenance of standards for the cable telecommunications industry. SCTE's standards mission is to develop standards that meet the needs of cable system operators, content providers, network and customer premises equipment manufacturers, and all others who have an interest in the industry through a fair, balanced and transparent process.

SCTE is currently seeking to broaden the membership base of its ANS consensus bodies and is interested in new members in all membership categories to participate in new work in fiber-optic networks, advanced advertising, 3D television, and other important topics. Of particular interest is membership from the content (program and advertising) provider and user communities. Membership in the SCTE Standards Program is open to all directly and materially affected parties as defined in SCTE's membership rules and operating procedures. More information is available at [www.scte.org](http://www.scte.org) or by e-mail from [standards@scte.org](mailto:standards@scte.org).

Membership in the SCTE Standards Program is open to all directly and materially affected parties as defined in SCTE's membership rules and operating procedures. More information is available at [www.scte.org](http://www.scte.org) or by e-mail from [standards@scte.org](mailto:standards@scte.org).

# Accreditation Announcements (Standards Developers)

---

## Approval of Reaccreditation – ASD

### AISC (American Institute of Steel Construction)

Effective February 5, 2021

The reaccreditation of the American Institute of Steel Construction (AISC), an ANSI Member and Accredited Standards Developer, has been approved at the direction of ANSI's Executive Standards Council under its recently revised operating procedures for documenting consensus on AISC-sponsored American National Standards, effective February 5, 2021. For additional information, please contact: Mr. Eric Bolin, Staff Engineer, American Institute of Steel Construction, 130 E. Randolph Street, Chicago, IL 60601-6204; phone: 312.670.5421; email: [bolin@aisc.org](mailto:bolin@aisc.org)

## Public Review of Revised ASD Operating Procedures

### ESTA (Entertainment Services and Technology Association)

Comment Deadline: March 10, 2021

The Entertainment Services and Technology Association (ESTA), an ANSI Member and Accredited Standards Developer, has submitted revisions to its currently accredited operating procedures for documenting consensus on ESTA-sponsored American National Standards under which it was last reaccredited in 2015. As the revisions appear to be substantive in nature, the reaccreditation process is initiated.

To obtain a copy of the revised procedures or to offer comments, please contact: Mr. Richard Nix, Asst. Technology Standards Manager, Entertainment Services and Technology Association, 271 Cadman Plaza, P.O. Box 23200; Brooklyn, NY 11202-3200; phone: 212.244.1505 ext. 649; email: [richard.nix@esta.org](mailto:richard.nix@esta.org). You may view/download a copy of the revisions during the public review period at the following URL: <https://share.ansi.org/Shared%20Documents/Forms/AllItems.aspx?RootFolder=%2FShared%20Documents%2FStandards%20Activities%2FPublic%20Review%20and%20Comment%2FANSI%20Accreditation%20Actions%2FFebruary%2012%20%2D%20March%2010%2C%202021%20Public%20Review%20Period&InitialTabId=Ribbon%2EDocument&VisibilityContext=WSSTabPersistence>

Please submit any public comments on the revised procedures to ESTA by March 10, 2021, with a copy to the ExSC Recording Secretary in ANSI's New York Office (E-mail: [Jthompo@ANSI.org](mailto:Jthompo@ANSI.org)).

## Withdrawal of ASD Accreditation

### NACF (North American Crossbow Federation)

Effective February 4, 2021

The North American Crossbow Federation (NACF) has requested the formal withdrawal of its accreditation as a developer of American National Standards (ANS), and of its sponsored-ANS:

Notice of Withdrawn NACF ANS

ANSI/NACF 001-2018, Criteria of Crossbow Designs Under Conditions of Reasonable Foreseeable Use and Abuse by Users

These actions were taken effective February 4, 2021. For additional information, please contact: Merle Shepard, 1325 Waterloo Road, Suffield, OH 44260 p: (313) 268-1727 e: [SCISHEP@aol.com](mailto:SCISHEP@aol.com).

# Accreditation Announcements (Standards Developers)

## Withdrawal of ASD Accreditation

### SHRM - Society for Human Resource Management

Effective February 4, 2021

The SHRM - Society for Human Resource Management has requested the formal withdrawal of its accreditation as a developer of American National Standards (ANS), and of its sponsored-ANS:

#### Notice of Withdrawn ANS

ANSI/SHRM 06001-2012, Cost Per Hire, (new standard)

ANSI/SHRM-09001-2012, Performance Management, (new standard)

#### Discontinuance of standards proposals

BSR/SHRM 02001-201X, Guidelines for Reporting Human Capital Metrics to Investors, (new standard)

BSR/SHRM 02004-202x, Talent Development Reporting Principles for Learning and Development, (new standard)

BSR/SHRM-02005-202x, Time to Hire, (new standard)

BSR/SHRM 06002-200x, Workforce Planning, (new standard)

BSR/SHRM 06003-200x, Workforce Planning, (new standard)

BSR/SHRM 06004-202x, Time To Proficiency, (new standard)

BSR/SHRM 06005-202x, Sourcing Metrics, (new standard)

BSR/SHRM 06006-202x, New Hire Performance, (new standard)

BSR/SHRM-06007-202x, Pre-employment Assessment Testing, (new standard)

BSR/SHRM-06008-202x, Adverse Impact Analysis, (new standard)

BSR/SHRM-10001-202x, Organizational Diversity and Inclusion Program, (new standard)

BSR/SHRM-10002-202x, Diversity Metrics Panel, (new standard)

BSR/SHRM-10003-202x, Lead Diversity/Inclusion Professional, (new standard)

BSR/SHRM-12001-202x, Training Needs Analysis, (new standard)

These actions were taken effective February 4, 2021. For additional information, please contact: Erica Banner, 1800 Duke Street, Alexandria, VA 22314 p: (703) 535-6025 e: erica.banner@shrm.org

# American National Standards (ANS) Process

---

Please visit ANSI's website ([www.ansi.org](http://www.ansi.org)) for resources that will help you to understand, administer and participate in the American National Standards (ANS) process. Documents posted at these links are updated periodically as new documents and guidance are developed, whenever ANS-related procedures are revised, and routinely with respect to lists of proposed and approved ANS. The main ANS-related link is [www.ansi.org/asd](http://www.ansi.org/asd) and here are some direct links as well as highlights of information that is available:

## Where to find Procedures, Guidance, Interpretations and More...

Please visit ANSI's website ([www.ansi.org](http://www.ansi.org))

- ANSI Essential Requirements: Due process requirements for American National Standards (always current edition): [www.ansi.org/essentialrequirements](http://www.ansi.org/essentialrequirements)
- ANSI Standards Action (weekly public review announcements of proposed ANS and standards developer accreditation applications, listing of recently approved ANS, and proposed revisions to ANS-related procedures): [www.ansi.org/standardsaction](http://www.ansi.org/standardsaction)
- Accreditation information – for potential developers of American National Standards (ANS): [www.ansi.org/sdoaccreditation](http://www.ansi.org/sdoaccreditation)
- ANS Procedures, ExSC Interpretations and Guidance (including a slide deck on how to participate in the ANS process and the BSR-9 form): [www.ansi.org/asd](http://www.ansi.org/asd)
- Lists of ANSI-Accredited Standards Developers (ASDs), Proposed ANS and Approved ANS: [www.ansi.org/asd](http://www.ansi.org/asd)
- American National Standards Key Steps: [www.ansi.org/anskeysteps](http://www.ansi.org/anskeysteps)
- American National Standards Value: [www.ansi.org/ansvalue](http://www.ansi.org/ansvalue)
- ANS Web Forms for ANSI-Accredited Standards Developers - PINS, BSR8|108, BSR11, Technical Report: <https://www.ansi.org/portal/psawebforms/>
- Information about standards Incorporated by Reference (IBR): <https://ibr.ansi.org/>
- ANSI - Education and Training: [www.standardslearn.org](http://www.standardslearn.org)

If you have a question about the ANS process and cannot find the answer, please email us at: [psa@ansi.org](mailto:psa@ansi.org) . Please also visit Standards Boost Business at [www.standardsboostbusiness.org](http://www.standardsboostbusiness.org) for resources about why standards matter, testimonials, case studies, FAQs and more.

If you are interested in purchasing an American National Standard, please visit <https://webstore.ansi.org>

# American National Standards Under Continuous Maintenance

The ANSI Essential Requirements: Due Process Requirements for American National Standards provides two options for the maintenance of American National Standards (ANS): periodic maintenance (see clause 4.7.1) and continuous maintenance (see clause 4.7.2). Continuous maintenance is defined as follows:

The standard shall be maintained by an accredited standards developer. A documented program for periodic publication of revisions shall be established by the standards developer. Processing of these revisions shall be in accordance with these procedures. The published standard shall include a clear statement of the intent to consider requests for change and information on the submittal of such requests. Procedures shall be established for timely, documented consensus action on each request for change and no portion of the standard shall be excluded from the revision process. In the event that no revisions are issued for a period of four years, action to reaffirm or withdraw the standard shall be taken in accordance with the procedures contained in the ANSI Essential Requirements.

The Executive Standards Council (ExSC) has determined that for standards maintained under the Continuous Maintenance option, separate PINS announcements are not required. The following ANSI Accredited Standards Developers have formally registered standards under the Continuous Maintenance option.

- 
- **AAMI (Association for the Advancement of Medical Instrumentation)**
  - **AARST (American Association of Radon Scientists and Technologists)**
  - **AGA (American Gas Association)**
  - **AGSC (Auto Glass Safety Council)**
  - **ASC X9 (Accredited Standards Committee X9, Incorporated)**
  - **ASHRAE (American Society of Heating, Refrigerating and Air-Conditioning Engineers, Inc.)**
  - **ASME (American Society of Mechanical Engineers)**
  - **ASTM (ASTM International)**
  - **GBI (Green Building Initiative)**
  - **HL7 (Health Level Seven)**
  - **IES (Illuminating Engineering Society)**
  - **ITI (InterNational Committee for Information Technology Standards)**
  - **MHI (Material Handling Industry)**
  - **NAHBRC (NAHB Research Center, Inc.)**
  - **NBBPVI (National Board of Boiler and Pressure Vessel Inspectors)**
  - **NCPDP (National Council for Prescription Drug Programs)**
  - **NEMA (National Electrical Manufacturers Association)**
  - **NISO (National Information Standards Organization)**
  - **NSF (NSF International)**
  - **PRCA (Professional Ropes Course Association)**
  - **RESNET (Residential Energy Services Network, Inc.)**
  - **SAE (SAE International)**
  - **TCNA (Tile Council of North America)**
  - **TIA (Telecommunications Industry Association)**
  - **UL (Underwriters Laboratories)**

To obtain additional information with regard to these standards, including contact information at the ANSI Accredited Standards Developer, please visit ANSI Online at [www.ansi.org/asd](http://www.ansi.org/asd), select "American National Standards Maintained Under Continuous Maintenance." Questions? [psa@ansi.org](mailto:psa@ansi.org).

# ANSI-Accredited Standards Developers Contacts

The addresses listed in this section are to be used in conjunction with standards listed in PINS, Call for Comment and Final Actions. This section is a list of developers who have submitted standards for this issue of *Standards Action* – it is not intended to be a list of all ANSI-Accredited Standards Developers. Please send all address corrections to Standards Action Editor at [standact@ansi.org](mailto:standact@ansi.org).

---

## AAFS

American Academy of Forensic Sciences  
410 North 21st Street  
Colorado Springs, CO 80904  
e: [tambrosius@aafs.org](mailto:tambrosius@aafs.org)  
p: (719) 453-1036  
[www.aafs.org](http://www.aafs.org)

## AAMI

Association for the Advancement of Medical Instrumentation  
901 N. Glebe Road  
Suite 300  
Arlington, VA 22203  
e: [cbernier@aami.org](mailto:cbernier@aami.org)  
p: (703) 253-8263  
[www.aami.org](http://www.aami.org)

## APTech (ASC CGATS)

Association for Print Technologies  
1896 Preston White Drive  
Reston, VA 20191  
e: [dorf@aptech.org](mailto:dorf@aptech.org)  
p: (703) 264-7200  
[www.printtechnologies.org](http://www.printtechnologies.org)

## ASHRAE

American Society of Heating, Refrigerating and Air-Conditioning Engineers, Inc.  
1791 Tullie Circle NE  
Atlanta, GA 30329  
e: [tmlisle@ashrae.org](mailto:tmlisle@ashrae.org)  
p: (678) 539-1111  
[www.ashrae.org](http://www.ashrae.org)

## ASIS

ASIS International  
1625 Prince Street  
Alexandria, VA 22314-2818  
e: [standards@asisonline.org](mailto:standards@asisonline.org)  
p: (703) 518-1439  
[www.asisonline.org](http://www.asisonline.org)

## ASTM

ASTM International  
100 Barr Harbor Drive  
West Conshohocken, PA 19428-2959  
e: [accreditation@astm.org](mailto:accreditation@astm.org)  
p: (610) 832-9744  
[www.astm.org](http://www.astm.org)

## ATIS

Alliance for Telecommunications Industry Solutions  
1200 G Street NW  
Suite 500  
Washington, DC 20005  
e: [dgreco@atis.org](mailto:dgreco@atis.org)  
p: (202) 628-6380  
[www.atis.org](http://www.atis.org)

## AWS

American Welding Society  
8669 NW 36th Street  
Suite 130  
Miami, FL 33166-6672  
e: [sborrero@aws.org](mailto:sborrero@aws.org)  
p: (305) 443-9353  
[www.aws.org](http://www.aws.org)

## AWWA

American Water Works Association  
6666 W. Quincy Avenue  
Denver, CO 80235  
e: [polson@awwa.org](mailto:polson@awwa.org)  
p: (303) 347-6178  
[www.awwa.org](http://www.awwa.org)

## BIFMA

Business and Institutional Furniture Manufacturers Association  
678 Front Avenue NW  
Grand Rapids, MI 49504  
e: [dpanning@bifma.org](mailto:dpanning@bifma.org)  
p: (616) 591-9798  
[www.bifma.org](http://www.bifma.org)

## CGA

Compressed Gas Association  
8484 Westpark Drive  
Suite 220  
McLean, VA 22102  
e: [kmastromichalis@cganet.com](mailto:kmastromichalis@cganet.com)  
p: (703) 788-2728  
[www.cganet.com](http://www.cganet.com)

## CTA

Consumer Technology Association  
1919 South Eads Street  
Arlington, VA 22202  
e: [vlancaster@cta.tech](mailto:vlancaster@cta.tech)  
p: (703) 907-7697  
[www.cta.tech](http://www.cta.tech)

## EOS/ESD

ESD Association, Inc.  
7902 Turin Road  
Building 3  
Rome, NY 13440-2069  
e: [laurenradmin@esda.org](mailto:laurenradmin@esda.org)  
p: (315) 339-6937  
[www.esda.org](http://www.esda.org)

**HPS (ASC N13)**

Health Physics Society  
1313 Dolley Madison Blvd #402  
McLean, VA 22101  
e: nanjohns@verizon.net  
p: (703) 790-1745  
www.hps.org

**IAPMO (ASSE Chapter)**

ASSE International Chapter of IAPMO  
18927 Hickory Creek Drive  
Suite 220  
Mokena, IL 60448  
e: terry.burger@asse-plumbing.org  
p: (909) 519-0740  
www.asse-plumbing.org

**IEEE (ASC C63)**

Institute of Electrical and Electronics  
Engineers  
445 Hoes Lane  
Piscataway, NJ 08854  
e: J.Santulli@ieee.org  
p: (732) 562-3874  
www.ieee.org

**IIAR**

International Institute of Ammonia  
Refrigeration  
1001 North Fairfax Street  
Alexandria, VA 22314  
e: tony\_lundell@iiar.org  
p: (703) 312-4200  
www.iiar.org

**ISA (Organization)**

International Society of Automation  
67 Alexander Drive  
Research Triangle Park, NC 27709  
e: crobinson@isa.org  
p: (919) 990-9213  
www.isa.org

**ITI (INCITS)**

InterNational Committee for  
Information Technology Standards  
700 K Street NW  
Suite 600  
Washington, DC 20001  
e: comments@standards.incits.org  
p: (202) 737-8888  
www.incits.org

**LIA (ASC Z136)**

Laser Institute of America  
12001 Research Parkway  
Suite 210  
Orlando, FL 32828  
e: lcaldero@lia.org  
p: (407) 380-1553  
www.laserinstitute.org

**NEMA (ASC W1)**

National Electrical Manufacturers  
Association  
1300 North 17th Street  
Rosslyn, VA 22209  
e: Khaled.Masri@nema.org  
p: (703) 841-3278  
www.nema.org

**NENA**

National Emergency Number  
Association  
1700 Diagonal Road  
Suite 500  
Alexandria, VA 22314  
e: darnold@nena.org  
p: (727) 312-3230  
www.nena.org

**NFPA**

National Fire Protection Association  
One Batterymarch Park  
Quincy, MA 02269-9101  
e: PFoley@nfpa.org  
p: (617) 984-7248  
www.nfpa.org

**NSF**

NSF International  
789 N. Dixboro Road  
Ann Arbor, MI 48105-9723  
e: arose@nsf.org  
p: (734) 827-3817  
www.nsf.org

**NSF**

NSF International  
789 N. Dixboro Road  
Ann Arbor, MI 48105-9723  
e: jsnider@nsf.org  
p: (734) 418-6660  
www.nsf.org

**NSF**

NSF International  
789 N. Dixboro Road  
Ann Arbor, MI 48105-9723  
e: rbrooker@nsf.org  
p: (734) 827-6866  
www.nsf.org

**SCTE**

Society of Cable Telecommunications  
Engineers  
140 Philips Rd  
Exton, PA 19341  
e: kcooney@scte.org  
p: (800) 542-5040  
www.scte.org

**SPRI**

Single Ply Roofing Industry  
465 Waverley Oaks Road  
Suite 421  
Waltham, MA 02452  
e: info@spri.org  
p: (781) 647-7026  
www.spri.org



**UL**

Underwriters Laboratories  
12 Laboratory Drive  
Research Triangle Park, NC 27709  
-3995  
e: jennifer.fields@ul.org  
p: (919) 549-1007  
<https://ul.org/>

**UL**

Underwriters Laboratories  
12 Laboratory Drive  
Research Triangle Park, NC 27709  
-3995  
e: kelly.smoke@ul.org  
p: (919) 316-5147  
<https://ul.org/>

**UL**

Underwriters Laboratories  
12 Laboratory Drive  
Research Triangle Park, NC 27709  
-3995  
e: Nicolette.A.Weeks@ul.org  
p: (919) 549-0973  
<https://ul.org/>

**UL**

Underwriters Laboratories  
12 Laboratory Drive  
Research Triangle Park, NC 27709  
-3995  
e: Tony.Partridge@ul.org  
p: (919) 549-1392  
<https://ul.org/>

**UL**

Underwriters Laboratories  
333 Pfingsten Road  
Northbrook, IL 60062  
e: megan.monsen@ul.org  
p: (847) 664-1292  
<https://ul.org/>

**UL**

Underwriters Laboratories  
333 Pfingsten Road  
Northbrook, IL 60062-2096  
e: mitchell.gold@ul.org  
p: (847) 664-2850  
<https://ul.org/>

**UL**

Underwriters Laboratories  
333 Pfingsten Road  
Northbrook, IL 60062-2096  
e: Susan.P.Malohn@ul.org  
p: (847) 664-1725  
<https://ul.org/>

**UL**

Underwriters Laboratories  
47173 Benicia Street  
Fremont, CA 94538  
e: Derrick.L.Martin@ul.org  
p: (510) 319-4271  
<https://ul.org/>



# ISO & IEC Draft International Standards

This section lists proposed standards that the International Organization for Standardization (ISO) and the International Electrotechnical Commission (IEC) are considering for approval. The proposals have received substantial support within the technical committees or subcommittees that developed them and are now being circulated to ISO and IEC members for comment and vote. Standards Action readers interested in reviewing and commenting on these documents should order copies from ANSI.

## COMMENTS

Comments regarding ISO documents should be sent to ANSI's ISO Team ([isot@ansi.org](mailto:isot@ansi.org)); comments on ISO documents must be submitted electronically in the approved ISO template and as a Word document as other formats will not be accepted.

Those regarding IEC documents should be sent to Tony Zertuche, General Secretary, USNC/IEC, at ANSI's New York offices ([tzertuche@ansi.org](mailto:tzertuche@ansi.org)). The final date for offering comments is listed after each draft.

## ORDERING INSTRUCTIONS

ISO and IEC Drafts can be made available by contacting ANSI's Customer Service department. Please e-mail your request for an ISO or IEC Draft to Customer Service at [sales@ansi.org](mailto:sales@ansi.org). When making your request, please provide the date of the Standards Action issue in which the draft document you are requesting appears.

## ISO Standards

### BANKING AND RELATED FINANCIAL SERVICES (TC 68)

ISO/DIS 4914, Financial services - Unique Product Identifier (UPI) - 4/30/2021, \$53.00

### COLLABORATIVE BUSINESS RELATIONSHIP MANAGEMENT -- FRAMEWORK (TC 286)

ISO/DIS 44004, Collaborative business relationship management - Guidelines for large organizations seeking collaboration with MSMEs - 4/26/2021, \$58.00

### GAS CYLINDERS (TC 58)

ISO/DIS 14246, Gas cylinders - Cylinder valves - Manufacturing tests and examinations - 5/1/2021, \$40.00

### INDUSTRIAL AUTOMATION SYSTEMS AND INTEGRATION (TC 184)

ISO/DIS 17506, Industrial automation systems and integration - COLLADA digital asset schema specification for 3D visualization of industrial data - 4/29/2021, \$269.00

### LIGHT METALS AND THEIR ALLOYS (TC 79)

ISO/DIS 18768-1, Organic coatings on aluminium and its alloys - Method for specifying decorative and protective organic coating on aluminium - Part 1: Powder coatings - 5/1/2021, \$93.00

ISO/DIS 18768-2, Organic coatings on aluminium and its alloys - Method for specifying decorative and protective organic coating on aluminium - Part 2: Liquid coatings - 5/1/2021, \$102.00

### NUCLEAR ENERGY (TC 85)

ISO/DIS 10645, Nuclear energy - Light water reactors - Decay heat power in non-recycled nuclear fuels - 5/1/2021, \$71.00

### PAINTS AND VARNISHES (TC 35)

ISO/DIS 17463, Paints and varnishes - Guidelines for the determination of anticorrosive properties of organic coatings by accelerated cyclic electrochemical technique - 5/1/2021, \$62.00

### REFRIGERATION (TC 86)

ISO/DIS 17584, Refrigerant properties - 4/24/2021, \$155.00

### ROAD VEHICLES (TC 22)

ISO/DIS 6627, Internal combustion engines - Piston rings - Expander/segment oil-control rings - 4/29/2021, \$62.00

ISO/DIS 31120-1, Road vehicles - injection water - Part 1: Quality requirements - 4/25/2021, \$53.00

### RUBBER AND RUBBER PRODUCTS (TC 45)

ISO/DIS 24376, Rubber, raw natural - Guidelines for technically specified low-protein natural rubber - 4/30/2021, \$58.00

### SUSTAINABLE DEVELOPMENT IN COMMUNITIES (TC 268)

ISO/DIS 37110, Sustainable cities and communities - Management guidelines of open data for smart cities and communities - Part 1: Overview and general principles - 5/2/2021, \$46.00

### TECHNICAL SYSTEMS AND AIDS FOR DISABLED OR HANDICAPPED PERSONS (TC 173)

ISO/DIS 7176-25, Wheelchairs - Part 25: Requirements and test methods for batteries and their chargers for electrically powered wheelchairs and motorized scooters - 11/13/2003, \$82.00

### TRACTORS AND MACHINERY FOR AGRICULTURE AND FORESTRY (TC 23)

ISO/DIS 13861, Machinery for forestry - Wheeled skidders - Terms, definitions and commercial specifications - 4/26/2021, FREE

ISO/DIS 13862, Machinery for forestry - Feller-bunchers - Terms, definitions and commercial specifications - 4/26/2021, FREE

**TRADITIONAL CHINESE MEDICINE (TC 249)**

ISO/DIS 23419, Traditional Chinese medicine - General requirement of manufacturing procedure and its quality assurance for granules - 4/26/2021, \$67.00

**TYRES, RIMS AND VALVES (TC 31)**

ISO 11795/DAMd1, - Amendment 1 - 4/29/2021, \$29.00

ISO/DIS 5383, Agricultural tyres for lawn and garden tractors - 3-part code designated tyres - 4/29/2021, \$67.00

**WASTE COLLECTION AND TRANSPORTATION MANAGEMENT (TC 297)**

ISO/DIS 24162, Test method of energy consumption of waste collection and transport vehicles - 5/1/2021, \$62.00

**ISO/IEC JTC 1, Information Technology**

ISO/IEC DIS 15909-3, Systems and software engineering - High-level petri nets - Part 3: Extensions and structuring mechanisms - 4/26/2021, \$62.00

ISO/IEC DIS 23093-1, Information technology - Internet of media things - Part 1: Architecture - 4/30/2021, \$82.00

ISO/IEC DIS 23090-12, Information technology - Coded representation of immersive media - Part 12: Immersive Video - 4/30/2021, \$146.00

**IEC Standards**

7/704/DTR, IEC TR 61597 ED2: Overhead electrical conductors - Calculation methods for stranded bare conductors, 04/02/2021

8A/75(F)/FDIS, IEC 62934 ED1: Grid integration of renewable energy generation - Terms and definitions, 02/26/2021

15/934/CD, IEC 60626-1 ED4: Combined flexible materials for electrical insulation - Part 1: Definitions and general requirements, 04/30/2021

18/1715/CD, IEC/IEEE 61886-2 ED1: Subsea equipment - Part 2: Power transformers, 04/30/2021

20/1950/CD, IEC 60287-1-1 ED3: Electric cables - Calculation of the current rating - Part 1-1: Current rating equations (100% load factor) and calculation of losses - General, 04/30/2021

20/1951/CD, IEC 60287-1-2 ED2: Electric cables - Calculation of the current rating - Part 1: Current rating equations (100% load factor) and calculations of losses - Section 2: Sheath eddy current loss factors for two circuits in flat formation, 04/30/2021

22F/604/CDV, IEC 60700-1/AMD1 ED2: Amendment 1 - Thyristor valves for high voltage direct current (HVDC) power transmission - Part 1: Electrical testing, 04/30/2021

22F/607/CDV, IEC 60700-2/AMD1 ED1: Amendment 1 - Thyristor valves for high voltage direct current (HVDC) power transmission - Part 2: Terminology, 04/30/2021

22F/608/CDV, IEC 61954 ED3: Static var compensators (SVC) - Testing of thyristor valves, 04/30/2021

23/969/DTR, IEC TR 63044-2 ED1: General requirements for Home and Building Electronic Systems (HBES) and Building Automation and Control Systems (BACS) - Part 2: Environmental conditions, 04/02/2021

26/716/FDIS, IEC 60974-11 ED4: Arc welding equipment - Part 11: Electrode holders, 03/19/2021

26/717/FDIS, IEC 60974-13 ED2: Arc welding equipment - Part 13: Welding current return clamp, 03/19/2021

31J/312/CDV, IEC 60079-17 ED6: Explosive atmospheres - Part 17: Electrical installations inspection and maintenance, 04/30/2021

32B/698(F)/FDIS, IEC 60269-6/AMD1 ED1: Low-voltage fuses - Part 6: Supplementary requirements for fuse-links for the protection of solar photovoltaic energy systems, 02/26/2021

34/795/DPAS, IEC PAS 63313 ED1: Global Lighting Association "Germicidal UV-C Irradiation - UV-C Safety Guidelines", 04/02/2021

34D/1600/CD, IEC 60598-2-2 ED4: Luminaires - Part 2-2: Particular requirements - Recessed luminaires, 04/30/2021

45A/1366(F)/CDV, IEC 63186 ED1: Nuclear power plants - Instrumentation and control systems important to safety - Criteria for seismic trip system, 04/02/2021

45A/1373(F)/FDIS, IEC/IEEE 63113 ED1: Nuclear facilities - Instrumentation important to safety - Spent fuel pool instrumentation, 02/19/2021

45A/1379/CD, IEC 62397 ED2: Nuclear power plants - Instrumentation and control systems important to safety - Resistance temperature detectors, 04/30/2021

46F/548(F)/FDIS, IEC 61169-60 ED1: Radio-frequency connectors - Part 60: Sectional specification for RF coaxial connectors with push on mating - Characteristic impedance 50 Ohm (type SMPM), 02/19/2021

46F/553/CD, IEC 61169-69 ED1: Radio Frequency Connectors - Part 69: Sectional specification for series SMP3 RF coaxial connectors, 04/30/2021

47/2687/FDIS, IEC 63229 ED1: Semiconductor devices - Classification of defects in gallium nitride epitaxial film on silicon carbide substrate, 03/19/2021

47/2688/CD, IEC 63287-2 ED1: Semiconductor devices - Guidelines for reliability qualification plans - Part 2: Concept of mission profile, 04/30/2021

47F/372/CDV, IEC 62047-40 ED1: Semiconductor devices - Micro-electromechanical devices - Part 40: Test methods of Micro-electromechanical inertial shock switch threshold, 04/30/2021

48D/736(F)/FDIS, IEC 61587-6 ED2: Mechanical structures for electrical and electronic equipment - Tests for IEC 60917 and IEC 60297 series - Part 6: Security aspects for indoor cabinets, 03/12/2021

- 64/2480(F)/FDIS, IEC 60364-7-710 ED2: Low-voltage electrical installations - Part 7-710: Requirements for special installations or locations - Medical locations, 02/26/2021
- 82/1865/CD, IEC TS 63217 ED1: Utility-interconnected photovoltaic (PV) inverters - Test procedure of over-voltage ride-through measurements, 04/02/2021
- 82/1866/NP, PNW 82-1866 ED1: Hybrid CPV/PV modules: General characteristics and measurement procedures - Part 1: Performance measurements and power rating - Irradiance and temperature, 04/02/2021
- 85/748(F)/CDV, IEC 60688 ED4: Electrical measuring transducers for converting AC and DC electrical quantities to analogue or digital signals, 04/23/2021
- 86A/2079(F)/FDIS, IEC 60794-4-30 ED1: Optical fibre cables - Part 4 -30: Aerial optical cables along electrical power lines - Family specification for optical phase conductor (OPPC) optical cables, 02/26/2021
- 86A/2086/FDIS, IEC 60794-3-70 ED2: Optical fibre cables - Part 3-70: Outdoor cables - Family specification for outdoor optical fibre cables for rapid/multiple deployment, 03/19/2021
- 86B/4407/CDV, IEC 61753-101-03 ED1: Fibre optic interconnecting devices and passive components performance standard - Part 101 -03: Fibre management systems for Category OP - Outdoor protected environment, 04/30/2021
- 86B/4408/CDV, IEC 61753-111-07 ED1: Fibre optic interconnecting devices and passive components performance standard - Part 111 -07: Sealed closures for category A - Aerial, 04/30/2021
- 86B/4409/CDV, IEC 61753-111-09 ED1: Fibre optic interconnecting devices and passive components performance standard - Part 111 -09: Sealed closures for category S - Subterranean, 04/30/2021
- 86B/4426/FDIS, IEC 61753-111-08 ED1: Fibre optic interconnecting devices and passive components - Performance standard - Part 111-08: Sealed closures for category G - Ground, 03/19/2021
- 86B/4427/CD, IEC TR 63323 ED1: Fibre optic interconnecting devices and passive components - A study of an SC connector adaptor with safety lock mechanism, 04/02/2021
- 86B/4431/NP, PNW 86B-4431 ED1: Fibre optic interconnecting devices and passive components - Fibre optic connector multimode optical interfaces - Part 2-2: Connection of 50 µm core diameter multimode physically contacting fibres - Non-angled for reference connector application, at wavelength of 850nm using selected A1-OM2 to A1-OM5 fibre only, 04/30/2021
- 86B/4432/DPAS, IEC PAS 63267-3-30 ED1: Fibre optic interconnecting devices and passive components - Fibre optic connector optical interfaces - Part 3-30: End face geometry angled PC end face PPS rectangular ferrule, multimode A1b fibres, 04/02/2021
- 86B/4433/CD, IEC 61300-3-4 ED4: Fibre optic interconnecting devices and passive components - Basic test and measurement procedures - Part 3-4: Examinations and measurements - Attenuation, 04/30/2021
- 88/795/CDV, IEC 61400-13/AMD1 ED1: Amendment 1 - Wind turbines - Part 13: Measurement of mechanical loads, 04/30/2021
- 88/800/NP, PNW TS 88-800 ED1: Decommissioning and preparation for recycling, 04/30/2021
- 90/462/FDIS, IEC 61788-17 ED2: Superconductivity - Part 17: Electronic characteristic measurements - Local critical current density and its distribution in large-area superconducting films, 03/19/2021
- 91/1697/CDV, IEC 61189-2-807 ED1: Test methods for electrical materials, printed board and other interconnection structures and assemblies - Part 2-807: Test methods for materials for interconnection structures - Decomposition Temperature (Td) using TGA, 04/30/2021
- 100/3562/CD, IEC 60728-113 ED2: Cable networks for television signals, sound signals and interactive services - Part 113: Optical systems for broadcast signal transmissions loaded with digital channels only, 04/02/2021
- 100/3563/CD, IEC 60728-106 ED1: Optical equipment for systems loaded with digital channels only, 04/02/2021
- 104/894/CD, IEC TR 62131-8 ED1: Environmental conditions - Vibration and shock of electrotechnical equipment - Part 8: Transportation by ship, 04/30/2021
- 110/1278/CDV, IEC 62977-3-7 ED1: Electronic displays - Part 3-7: Evaluation of optical performances - Tone characteristics, 04/30/2021
- 110/1279/CDV, IEC 62906-5-1 ED1: Laser displays - Part 5-1: Measurement of optical performance for laser front projection, 04/02/2021
- 113/579/DTS, IEC TS 62607-6-6 ED1: Nanomanufacturing - Key control characteristics - Part 6-6: Graphene-based materials - Strain uniformity: Spatially-resolved Raman spectroscopy, 04/30/2021
- 119/346/FDIS, IEC 62899-402-3 ED1: Printed electronics - Part 402 -3: Printability - Measurement of qualities - Voids in printed pattern using two-dimensional optical image, 03/19/2021
- CIS/B/759/CD, CISPR 11/FRAG6 ED7: Fragment 6: Requirements for radiated emissions above 1 GHz, 04/30/2021
- CIS/B/760/CD, CISPR 11/FRAG7 ED7: Fragment 7: Requirements for radio enabled products, 04/30/2021
- CIS/B/761/CD, CISPR 11/FRAG2 ED7: Fragment 2: Miscellaneous, definitions and annexes, 04/30/2021
- SyCLVDC/101/CD, IEC 63318 ED1: Electricity access requirements with SELV DC for Tier II and Tier III of ESMAP multi-tier framework for household electricity supply, 04/30/2021
- JTC1-SC25/2999/CDV, ISO/IEC 14165-432: Information technology - Fibre channel - Part 432: Security protocols - 2 (FC-SP-2), 04/30/2021
- JTC1-SC25/3012/FDIS, ISO/IEC 17760-103 ED1: Information technology - AT Attachment - Part 103: ATA/ATAPI Command Set - 3 (ACS-3), 04/02/2021

JTC1-SC25/3013/NP, PNW JTC1-SC25-3013 ED1: ISO/IEC 15067-3-30:  
Information technology - Home Electronic System (HES)  
application model - EMA functional requirements and interfaces,  
04/30/2021

JTC1-SC41/208/CD, ISO/IEC 30171 ED1: Internet of Things (IoT) -  
Overview and requirements for Base-station based Underwater  
Wireless Acoustic Network (B-UWAN), 04/02/2021



# Newly Published ISO & IEC Standards

Listed here are new and revised standards recently approved and promulgated by ISO - the International Organization for Standardization – and IEC – the International Electrotechnical Commission. Most are available at the ANSI Electronic Standards Store (ESS) at [www.ansi.org](http://www.ansi.org). All paper copies are available from Standards resellers (<http://webstore.ansi.org/faq.aspx#resellers>).

## ISO Standards

### AGRICULTURAL FOOD PRODUCTS (TC 34)

[ISO 22184:2021](#), Milk and milk products - Determination of the sugar contents - High performance anion exchange chromatography with pulsed amperometric detection method (HPAEC-PAD), \$149.00

### AIRCRAFT AND SPACE VEHICLES (TC 20)

[ISO 23665:2021](#), Unmanned aircraft systems - Training for personnel involved in UAS operations, \$175.00

### BAMBOO AND RATTAN (TC 296)

[ISO 23066:2021](#), Vocabulary related to rattan materials and products, \$48.00

### BANKING AND RELATED FINANCIAL SERVICES (TC 68)

[ISO 6166:2021](#), Financial services - International securities identification number (ISIN), \$111.00

### BUILDING ENVIRONMENT DESIGN (TC 205)

[ISO 52127-1:2021](#), Energy performance of buildings - Building management system - Part 1: Module M10-12, \$111.00

### DIMENSIONAL AND GEOMETRICAL PRODUCT SPECIFICATIONS AND VERIFICATION (TC 213)

[ISO 22081:2021](#), Geometrical product specifications (GPS) - Geometrical tolerancing - General geometrical specifications and general size specifications, \$111.00

### DOCUMENTS AND DATA ELEMENTS IN ADMINISTRATION, COMMERCE AND INDUSTRY (TC 154)

[ISO 19626-2:2021](#), Processes, data elements and documents in commerce, industry and administration - Trusted communication platform for electronic documents - Part 2: Applications, \$225.00

### FURNITURE (TC 136)

[ISO 24496:2021](#), Office furniture - Office chairs - Methods for the determination of dimensions, \$225.00

### REFRIGERATION (TC 86)

[ISO 21978:2021](#), Heat pump water heater - Testing and rating at part load conditions and calculation of seasonal coefficient of performance for space heating, \$200.00

### ROBOTS AND ROBOTIC DEVICES (TC 299)

[ISO 22166-1:2021](#), Robotics - Modularity for service robots - Part 1: General requirements, \$225.00

### SHAFTS FOR MACHINERY AND ACCESSORIES (TC 14)

[ISO 4156-1:2021](#), Straight cylindrical involute splines - Metric module, side fit - Part 1: Generalities, \$225.00

[ISO 4156-2:2021](#), Straight cylindrical involute splines - Metric module, side fit - Part 2: Dimensions, \$250.00

[ISO 4156-3:2021](#), Straight cylindrical involute splines - Metric module, side fit - Part 3: Inspection, \$200.00

### SHIPS AND MARINE TECHNOLOGY (TC 8)

[ISO 15372/Amd1:2021](#), Ships and marine technology - Inflatable rescue boats - Coated fabrics for inflatable chambers - Amendment 1: Oil-resistance test, \$20.00

### SMALL CRAFT (TC 188)

[ISO 7840:2021](#), Small craft - Fire-resistant fuel hoses, \$73.00

[ISO 8469:2021](#), Small craft - Non-fire-resistant fuel hoses, \$73.00

### TOBACCO AND TOBACCO PRODUCTS (TC 126)

[ISO 19290:2021](#), Cigarettes - Determination of tobacco specific nitrosamines in mainstream cigarette smoke - Method using LC-MS/MS, \$111.00

[ISO 21766:2021](#), Tobacco and tobacco products - Determination of tobacco-specific nitrosamines in tobacco products - Method using LC-MS/MS, \$111.00

### TRANSFUSION, INFUSION AND INJECTION EQUIPMENT FOR MEDICAL USE (TC 76)

[ISO 8536-12:2021](#), Infusion equipment for medical use - Part 12: Check valves for single use, \$73.00

## ISO Technical Reports

### BUILDING ENVIRONMENT DESIGN (TC 205)

[ISO/TR 52127-2:2021](#), Energy performance of buildings - Building automation, controls and building management - Part 2: Explanation and justification of ISO 52127-1, \$73.00

### CARBON DIOXIDE CAPTURE, TRANSPORTATION, AND GEOLOGICAL STORAGE (TC 265)

[ISO/TR 27922:2021](#), Carbon dioxide capture - Overview of carbon dioxide capture technologies in the cement industry, \$111.00

### SAFETY OF MACHINERY (TC 199)

[ISO/TR 22053:2021](#), Safety of machinery - Safeguarding supportive system, \$73.00

### TRANSPORT INFORMATION AND CONTROL SYSTEMS (TC 204)

[ISO/TR 21186-3:2021](#), Cooperative intelligent transport systems (C-ITS) - Guidelines on the usage of standards - Part 3: Security, \$250.00

## ISO Technical Specifications

### HUMAN RESOURCE MANAGEMENT (TC 260)

[ISO/TS 30423:2021](#), Human resource management - Compliance and ethics metrics cluster, \$111.00

### ISO/IEC JTC 1, Information Technology

[ISO/IEC 11770-4/Amd2:2021](#), Information technology - Security techniques - Key management - Part 4: Mechanisms based on weak secrets - Amendment 2: Leakage-resilient password-authenticated key agreement with additional stored secrets, \$73.00

[ISO/IEC 23761:2021](#), Digital publishing - EPUB accessibility - Conformance and discoverability requirements for EPUB publications, \$73.00

## IEC Standards

### CAPACITORS AND RESISTORS FOR ELECTRONIC EQUIPMENT (TC 40)

[IEC 60384-15 Ed. 2.0 b:2017](#), Fixed capacitors for use in electronic equipment - Part 15: Sectional specification: Fixed tantalum capacitors with non-solid or solid electrolyte, \$259.00

### ELECTRIC CABLES (TC 20)

[IEC 60502-SER Ed. 1.0 b:2021](#), Power cables with extruded insulation and their accessories for rated voltages from 1 kV (Um = 1,2 kV) up to 30 kV (Um = 36 kV) - ALL PARTS, \$1045.00

[IEC 60840 Ed. 5.0 b cor.1:2021](#), Corrigendum 1 - Power cables with extruded insulation and their accessories for rated voltages above 30 kV (Um = 36 kV) up to 150 kV (Um = 170 kV) - Test methods and requirements, \$0.00

[IEC 60502-1 Ed. 3.0 en:2021](#), Power cables with extruded insulation and their accessories for rated voltages from 1 kV (Um = 1,2 kV) up to 30 kV (Um = 36 kV) - Part 1: Cables for rated voltages of 1 kV (Um = 1,2 kV) and 3 kV (Um = 3,6 kV), \$354.00

[S+ IEC 60502-1 Ed. 3.0 en:2021 \(Redline version\)](#), Power cables with extruded insulation and their accessories for rated voltages from 1 kV (Um = 1,2 kV) up to 30 kV (Um = 36 kV) - Part 1: Cables for rated voltages of 1 kV (Um = 1,2 kV) and 3 kV (Um = 3,6 kV), \$460.00

### ELECTRICAL ACCESSORIES (TC 23)

[IEC 60669-2-1 Ed. 5.0 b:2021](#), Switches for household and similar fixed electrical installations - Part 2-1: Particular requirements - Electronic control devices, \$430.00

### FIBRE OPTICS (TC 86)

[IEC 61291-5-2 Ed. 2.0 b:2017](#), Optical amplifiers - Part 5-2: Qualification specifications - Reliability qualification for optical fibre amplifiers, \$89.00

[IEC 60793-1-34 Ed. 3.0 b:2021](#), Optical fibres - Part 1-34: Measurement methods and test procedures - Fibre curl, \$133.00

[IEC 60793-1-60 Ed. 1.0 b:2017](#), Optical fibres - Part 1-60: Measurement methods and test procedures - Beat length, \$133.00

[IEC 61300-2-55 Ed. 1.0 b:2017](#), Fibre optic interconnecting devices and passive components - Basic test and measurement procedures - Part 2-55: Tests - Strength of mounted adaptor, \$89.00

[IEC 61300-3-43 Ed. 1.0 b:2009](#), Fibre optic interconnecting devices and passive components - Basic test and measurement procedures - Part 3-43: Examinations and measurements - Mode transfer function measurement for fibre optic sources, \$133.00

[S+ IEC 60793-1-34 Ed. 3.0 en:2021 \(Redline version\)](#), Optical fibres - Part 1-34: Measurement methods and test procedures - Fibre curl, \$173.00

### INDUSTRIAL-PROCESS MEASUREMENT AND CONTROL (TC 65)

[IEC 62769-1 Ed. 2.0 b:2021](#), Field Device Integration (FDI) - Part 1: Overview, \$259.00

[IEC 62769-2 Ed. 2.0 b:2021](#), Field Device Integration (FDI) - Part 2: FDI Client, \$430.00

[IEC 62769-3 Ed. 2.0 b:2021](#), Field Device Integration (FDI) - Part 3: Server, \$392.00

[IEC 62769-4 Ed. 2.0 b:2021](#), Field Device Integration (FDI) - Part 4: FDI Packages, \$392.00

[IEC 62769-5 Ed. 2.0 b:2021](#), Field Device Integration (FDI) - Part 5: Information Model, \$392.00

[IEC 62769-6 Ed. 2.0 b:2021](#), Field Device Integration (FDI) - Part 6: Technology Mapping, \$221.00

[IEC 62769-7 Ed. 2.0 b:2021](#), Field Device Integration (FDI) - Part 7: Communication Devices, \$392.00

[IEC 61158-5-4 Ed. 3.0 b:2019](#), Industrial communication networks - Fieldbus specifications - Part 5-4: Application layer service definition - Type 4 elements, \$392.00

[IEC 61158-5-21 Ed. 2.0 b:2019](#), Industrial communication networks - Fieldbus specifications - Part 5-21: Application layer service definition - Type 21 elements, \$392.00

[IEC 61158-5-23 Ed. 2.0 b:2019](#), Industrial communication networks - Fieldbus specifications - Part 5-23: Application layer service definition - Type 23 elements, \$417.00

[IEC 61158-6-12 Ed. 4.0 b:2019](#), Industrial communication networks - Fieldbus specifications - Part 6-12: Application layer protocol specification - Type 12 elements, \$430.00

[IEC 61158-6-23 Ed. 2.0 b:2019](#), Industrial communication networks - Fieldbus specifications - Part 6-23: Application layer protocol specification - Type 23 elements, \$443.00

[IEC 62769-150-1 Ed. 1.0 b:2021](#), Field device integration (FDI) - Part 150-1: Profiles - ISA100 WIRELESS, \$221.00

[S+ IEC 62769-1 Ed. 2.0 en:2021 \(Redline version\)](#), Field Device Integration (FDI) - Part 1: Overview, \$338.00

[S+ IEC 62769-2 Ed. 2.0 en:2021 \(Redline version\)](#), Field Device Integration (FDI) - Part 2: FDI Client, \$559.00

[S+ IEC 62769-3 Ed. 2.0 en:2021 \(Redline version\)](#), Field Device Integration (FDI) - Part 3: Server, \$510.00

[S+ IEC 62769-4 Ed. 2.0 en:2021 \(Redline version\)](#), Field Device Integration (FDI) - Part 4: FDI Packages, \$510.00

[S+ IEC 62769-5 Ed. 2.0 en:2021 \(Redline version\)](#), Field Device Integration (FDI) - Part 5: Information Model, \$510.00

[S+ IEC 62769-6 Ed. 2.0 en:2021 \(Redline version\)](#), Field Device Integration (FDI) - Part 6: Technology Mapping, \$288.00

[S+ IEC 62769-7 Ed. 2.0 en:2021 \(Redline version\)](#), Field Device Integration (FDI) - Part 7: Communication Devices, \$510.00

## MARITIME NAVIGATION AND RADIOCOMMUNICATION EQUIPMENT AND SYSTEMS (TC 80)

[IEC 61162-3 Ed. 1.0 b:2008](#), Maritime navigation and radiocommunication equipment and systems - Digital interfaces - Part 3: Serial data instrument network, \$133.00

## PRIMARY CELLS AND BATTERIES (TC 35)

[IEC 62281 Ed. 4.1 b:2021](#), Safety of primary and secondary lithium cells and batteries during transport, \$354.00

[IEC 62281 Amd.1 Ed. 4.0 b:2021](#), Amendment 1 - Safety of primary and secondary lithium cells and batteries during transport, \$13.00

## SOLAR PHOTOVOLTAIC ENERGY SYSTEMS (TC 82)

[IEC 61215-1-2 Ed. 2.0 b:2021](#), Terrestrial photovoltaic (PV) modules - Design qualification and type approval - Part 1-2: Special requirements for testing of thin-film Cadmium Telluride (CdTe) based photovoltaic (PV) modules, \$51.00

[S+ IEC 61215-1-2 Ed. 2.0 en:2021 \(Redline version\)](#), Terrestrial photovoltaic (PV) modules - Design qualification and type approval - Part 1-2: Special requirements for testing of thin-film Cadmium Telluride (CdTe) based photovoltaic (PV) modules, \$66.00

## SURFACE MOUNTING TECHNOLOGY (TC 91)

[IEC 60194-1 Ed. 1.0 b:2021](#), Printed boards design, manufacture and assembly - Vocabulary - Part 1: Common usage in printed board and electronic assembly technologies, \$443.00

[IEC 61188-6-2 Ed. 1.0 b:2021](#), Circuit boards and circuit board assemblies - Design and use - Part 6-2: Land pattern design - Description of land pattern for the most common surface mounted components (SMD), \$183.00

## SURGE ARRESTERS (TC 37)

[IEC 60099-5 Ed. 3.0 b:2018](#), Surge arresters - Part 5: Selection and application recommendations, \$443.00

## TERMINOLOGY (TC 1)

[IEC 60050-801 Amd.2 Ed. 2.0 b:2021](#), Amendment 2 - International Electrotechnical Vocabulary (IEV) - Part 801: Acoustics and electroacoustics, \$183.00

## IEC Technical Reports

### NUCLEAR INSTRUMENTATION (TC 45)

[IEC/TR 63335 Ed. 1.0 en:2021](#), Nuclear power plants - Instrumentation and control systems, control rooms and electrical power systems - Specific features of small modular reactors and needs regarding standards, \$221.00



## **IEC Technical Specifications**

### **SOLAR PHOTOVOLTAIC ENERGY SYSTEMS (TC 82)**

[IEC/TS 63156 Ed. 1.0 en:2021](#), Photovoltaic systems - Power conversion equipment performance - Energy evaluation method, \$183.00

### **SOLAR THERMAL ELECTRIC PLANTS (TC 117)**

[IEC/TS 62862-2-1 Ed. 1.0 en:2021](#), Solar thermal electric plants - Part 2-1: Thermal energy storage systems - Characterization of active, sensible systems for direct and indirect configurations, \$310.00

# International Organization for Standardization (ISO)

---

## Call for U.S. TAG Administrator

### ISO/TC 118/SC 3 – Pneumatic tools and machines

ANSI has been informed that the Compressed Air & Gas Institute (CAGI), the ANSI-accredited U.S. TAG Administrator for ISO/TC 118 - Compressors and pneumatic tools, machines and equipment, wishes to relinquish their role as U.S. TAG Administrator of ISO/TC 118/SC 3 – Pneumatic tools and machines. (CAGI will retain the U.S. TAG Administrator role for ISO/TC 118.)

ISO/TC 118/SC 3 operates under the following scope:

Standardization in the field of pneumatic tools and machines.

Exception: Pneumatic tool shanks and tool fitting dimensions as they fall within the scope of ISO/TC 29.

Note: Definitions of hydraulic tools and machines are included.

Organizations interested in serving as the U.S. TAG Administrator or participating on a U.S. TAG should contact ANSI's ISO Team ([isot@ansi.org](mailto:isot@ansi.org)).

# International Organization for Standardization (ISO)

## ISO Proposal for a New Field of ISO Technical Activity

### Assistance Dogs

**Comment Deadline: February 26, 2021**

NEN, the ISO member body for [Netherlands], has submitted to ISO a proposal for a new field of ISO technical activity on Assistance Dogs, with the following scope statement:

Standardization in the field of assistance dogs focused on, but not limited to:

- terminology
- health and welfare
- breeding and puppy development
- training
- client services
- assistance dog professionals
- conformity assessment, and
- accessibility

Assistance dogs are specifically trained to perform tasks to increase independence and to mitigate limitations of a person with a disability.

Excluded are:

- dogs that offer only emotional support and/or comfort (i.e. emotional support dogs)
- dog assisted interventions such as facility dogs or dog assisted therapy
- other kinds of working dogs such as herding dogs, police dogs, search & rescue dogs

Background information:

An assistance dog is permanently paired with a person with a disability to perform on a one-to-one basis tasks to mitigate the limitations of this person.

Please note that 'assistance dog' is the umbrella term. Examples of assistance dogs (in alphabetical order) are autism assistance dogs, developmental disorder assistance dogs, diabetes assistance dogs, guide dogs, hearing dogs, medical alert/response assistance dogs, mobility assistance dogs, PTSD assistance dogs, seizure assistance dogs.

In some countries, an assistance dog is referred to as a service dog.

Anyone wishing to review the proposal can request a copy by contacting ANSI's ISO Team ([isot@ansi.org](mailto:isot@ansi.org)), with a submission of comments to Steve Cornish ([scornish@ansi.org](mailto:scornish@ansi.org)) by close of business on Friday, February 26, 2021.

# Registration of Organization Names in the United States

---

The Procedures for Registration of Organization Names in the United States of America (document ISSB 989) require that alphanumeric organization names be subject to a 90-day Public Review period prior to registration. For further information, please contact the Registration Coordinator at (212) 642-4975.

When organization names are submitted to ANSI for registration, they will be listed here alphanumerically.

Alphanumeric names appearing for the first time are printed in bold type. Names with confidential contact information, as requested by the organization, list only public review dates.

## Public Review

### DISH Wireless

#### Comments Deadline: February 12, 2021

NOTE: Challenged alphanumeric names are underlined. The Procedures for Registration provide for a challenge process, which follows in brief. For complete details, see Section 6.4 of the Procedures.

A challenge is initiated when a letter from an interested entity is received by the Registration Coordinator. The letter shall identify the alphanumeric organization name being challenged and state the rationale supporting the challenge. A challenge fee shall accompany the letter. After receipt of the challenge, the alphanumeric organization name shall be marked as challenged in the Public Review list. The Registration Coordinator shall take no further action to register the challenged name until the challenge is resolved among the disputing parties.

# Proposed Foreign Government Regulations

---

## Call for Comment

U.S. manufacturers, exporters, regulatory agencies and standards developing organizations may be interested in proposed foreign technical regulations notified by Member countries of the World Trade Organization (WTO). In accordance with the WTO Agreement on Technical Barriers to Trade (TBT Agreement), Members are required to notify proposed technical regulations that may significantly affect trade to the WTO Secretariat in Geneva, Switzerland. In turn the Secretariat issues and makes available these notifications. The purpose of the notification requirement is to provide global trading partners with an opportunity to review and comment on the regulations before they become final.

The USA Inquiry Point for the WTO TBT Agreement is located at the National Institute of Standards and Technology (NIST) in the Standards Coordination Office (SCO). The Inquiry Point distributes the notified proposed foreign technical regulations (notifications) and makes the associated full-texts available to U.S. stakeholders via its online service, Notify U.S. Interested U.S. parties can register with Notify U.S. to receive e-mail alerts when notifications are added from countries and industry sectors of interest to them. To register for Notify U.S., please visit: <http://www.nist.gov/notifyus/>

The USA WTO TBT Inquiry Point is the official channel for distributing U.S. comments to the network of WTO TBT Enquiry Points around the world. U.S. business contacts interested in commenting on the notifications are asked to review the comment guidance available on Notify U.S. at: <https://tsapps.nist.gov/notifyus/data/guidance/guidance.cfm> prior to submitting comments.

For further information about the USA TBT Inquiry Point, please visit: <https://www.nist.gov/standardsgov/what-we-do/trade-regulatory-programs/usa-wto-tbt-inquiry-point> Contact the USA TBT Inquiry Point at (301) 975-2918; F: (301) 926-1559; E: [usatbtep@nist.gov](mailto:usatbtep@nist.gov) or [notifyus@nist.gov](mailto:notifyus@nist.gov).

# BSR/IIAR CO2-202x

## Safety Standard for Closed-Circuit Carbon Dioxide Refrigeration Systems

### IIAR CO2 Public Review #4 Draft

Following are supplementary instructions for submitting comments:

- 1) Provide all of the commenter's contact information [e.g. name, phone number(s), and e-mail].
- 2) Identify the specific Section (i.e., by its Chapter and Section number) that is the subject of each comment(s). Only changes resulting from Public Review #3 comments and enough content for understanding is shown. Eight (8) highlighted "Note Only:" comments are included to help with understanding. Only ~~striked-through~~ or underlined items can be commented on.
- 3) Provide specific wording changes or action that would resolve the commenter's concern(s). Additions should be shown by underlining and deletions by strikethrough (i.e., Addition: include this, Deletion: ~~remove this~~), unless clearly shown in another method.
- 4) Provide a brief substantiation statement that presents the rationale, justification, and supporting documentation; as well as any technical data and backup. Provide an abstract for lengthy substantiations. If supplementary documents are provided to support your comment(s), electronic files in word processed (MS Word preferred) or scanned form are preferred. Indicate whether attachments have been provided. Highlighting pens should not be used since highlighted text will not reproduce.
- 5) If you do not understand the material, proceed with doing the necessary homework to gain understanding of the material and/or call the IIAR to discuss before commenting. Do not submit comments as opinions or questions.

**International Institute of Ammonia Refrigeration**

**1001 North Fairfax Street, Suite 503**

**Alexandria, VA 22314**

**Phone: (703) 312-4200**

**Fax: (703) 312-0065**

**[www.iiar.org](http://www.iiar.org)**

# TITLE: Safety Standard for Closed-Circuit Carbon Dioxide Refrigeration Systems

## Chapter 1. Purpose, Scope, and Applicability

1.2.2 This standard also applies to:

3. \*The part of refrigeration systems utilizing carbon dioxide as a secondary fluid.

Note Only: An Asterisk (\*) was added above to Section 1.2.2, Item 3 and the following statement was added to (Informative) Appendix A, as Section A.1.2.2, Item 3:

A.1.2.2, Item 3: The intent of this standard is that if carbon dioxide is used in a closed-circuit, regardless if it undergoes a phase change or not, that portion of the system is within the scope of this standard. This includes secondary coolant circuits utilizing carbon dioxide even if the primary refrigeration circuit does not utilize carbon dioxide refrigerant.

## Chapter 2. Definitions

2.1 **General.** Definitions shall be in accordance with this chapter and ANSI/IIAR-1.

## Chapter 4. Location of Refrigeration Equipment

- 4.2.1 \*Listed Equipment. Equipment constructed and installed in accordance with the listing and the manufacturer's instructions shall be permitted in any occupancy without a machinery room.

Note Only: An asterisk (\*) was added above to Section 4.2.1 and the following statement was added to (Informative) Appendix A, as Section A.4.2.1:

A.4.2.1 "Listed" is defined in ANSI/IIAR 1.

Note Only: Section 2.1 above refers to ANSI/IIAR 1.

## 5.13 Signage, Labels, Pipe Marking

5.13.1 **Installation Identification.** Each refrigeration system erected on the premises shall be provided with a legible permanent sign, securely attached and easily accessible, indicating:

1. The name of and address of the installer.
2. The ASHRAE refrigerant ~~number~~ designation and amount of refrigerant.
3. The lubricant identity and amount.
4. The field test pressure(s) applied.

*BSR/IIAR CO2-202X Public Review #4 Draft*

5. The installation date.

~~6.9.3.5—Machinery room exhaust shall discharge to the outdoors in such a manner as not to cause a nuisance or danger.~~

Note Only: Other subsections of Section 6.9.3 cover this.

~~7.2.10—Occupancy. The floor area per occupant is not less than 100 ft<sup>2</sup> (9.3 m<sup>2</sup>).~~

Note Only: The 100 ft<sup>2</sup> was from prior editions of the industrial area exception to machinery room requirements, that have been deleted from the UMC, IMC, and ASHRAE 15.

9.2.2.6 \*UNS C19400 seamless copper tubing for refrigeration use is permitted for both subcritical and trans-critical systems when listed.

Note Only: The last two (2) sentences of (Informative) Appendix A, Section A.9.2.2.6 were modified as follows:

**A.9.2.2.6** High pressure copper tube has been developed that is made from UNS C19400 (aka. Copper-iron, CuFe2P, etc.) The tube is made to meet the dimensional (OD), mechanical, cleanness, and eddy current testing requirements of ASTM B280 (Seamless Copper Tube for Refrigeration Field Service). Similarly, the fittings are made to meet the dimensional requirements and other applicable specifications of ASME B16.22 (WROUGHT Copper and copper alloy...Pressure Fittings). At this time, an ASTM designation is pending for this material. In the meantime, listing is the basis for allowing this material. ~~This third party recognized tubing is available for refrigeration applications with continuous operating pressures of up to 1885 psig (130 Bar) at up to 250 °F (120 °C). Fitting MAWP is limited to 1740 psig (120 bar).~~ as verified and approved by UL 207. These third party recognized tubing and fittings are available for applications with a MAWP rating of up to 1885 psig (130 Bar) at up to 250 °F (120 °C).

## Chapter 13. Refrigerant Detection and Alarms

13.6.1 **Level 1 Carbon Dioxide Detection and Alarm.** Level 1 carbon dioxide detection and alarm shall have the following features:

1. At least one carbon dioxide detector shall be provided in the room or area.
2. The detector shall activate an audible and visual alarm at an indicated carbon dioxide concentration of: no greater than 5,000 ppm.

~~a.—Carbon Dioxide at 5,000 ppm or lower.~~

Note Only: The owner can activate a detector at a lower concentration if they choose to do so.



## Chapter 17. Insulation

~~17.1.1 All exterior refrigerant lines which require insulation shall have an insulation thickness selected to minimize condensation.~~

Note Only: The requirements for insulation are covered in Section 5.9.

CONFIDENTIAL

Not for publication. This document is part of the NSF International standard development process. This draft text is for circulation for review and/or approval by a NSF Standards Committee and has not been published or otherwise officially adopted. All rights reserved. This document may be reproduced for informational purposes only.

[Note – the recommended changes to the standard which include the current text of the relevant section(s) indicate deletions by use of ~~strikeout~~ and additions by **gray highlighting**. Rationale statements are in *italics* and only used to add clarity; these statements will NOT be in the finished publication.]

NSF/ANSI Standard  
for Good Manufacturing Practices –

# Good Manufacturing Practices for Dietary Supplements

- 
- 
- 

## 4 Audit requirements

- 
- 
- 

### 4.5 Operation

- 
- 
- 

4.5.14 Procedures shall be established for cleaning of the plant. [21 CFR § 111.16]

4.5.15 The plant shall have a documented preventive maintenance program.

~~4.5.16~~ All equipment, instruments, utensils, contact surfaces, etc., shall be maintained, cleaned and sanitized (to include disassembly as required by procedure) as necessary. [21 CFR § 111.27(d)]

- 
- 
- 

*Rationale: This was started by ARG issue paper #8. It was decided in a JC meeting on 12/17/20 to create a new standard issue.*

SPRI/FM BPT-1 20XX

Test Standard for Comparative Pull-Through Strengths of Insulation Fastening Systems and Substrate Board Materials Used with Low Slope Roofing Systems

Proposed Substantive Revision

2.2 Apparatus

- 2.2.1 A tensile test machine that applies load with a constant rate of speed and can measure the applied load. The equipment shall be calibrated within 12 months of the date of testing, in accordance with a standard that is traceable to a nationally recognized source. The load cell shall be of appropriate load capacity to ensure accurate results. See Commentary 2.2.1.

## UL 508A, Standard for Safety for Industrial Control Panels

### 8. Current Limiting Reactor (CLR) – Withdrawal of Proposal

***If the July 10, 2020 proposal is withdrawn, the current requirements in the standard would remain unchanged, and the addition of new Clause SB4.3.5 would no longer be included.***

~~SB4.3.5 For branch circuits provided with a Current Limiting Reactor (CLR) in the feeder circuit, the short circuit current rating shall be calculated by according the following:~~

~~For a current limiting reactor with a marked or known impedance (x%) the available short circuit current shall be determined by dividing the system voltage by the equivalent impedance ( $Z_{eq}$ ) of the combined power system, inclusive the series CLR at the point of fault, as follows:~~

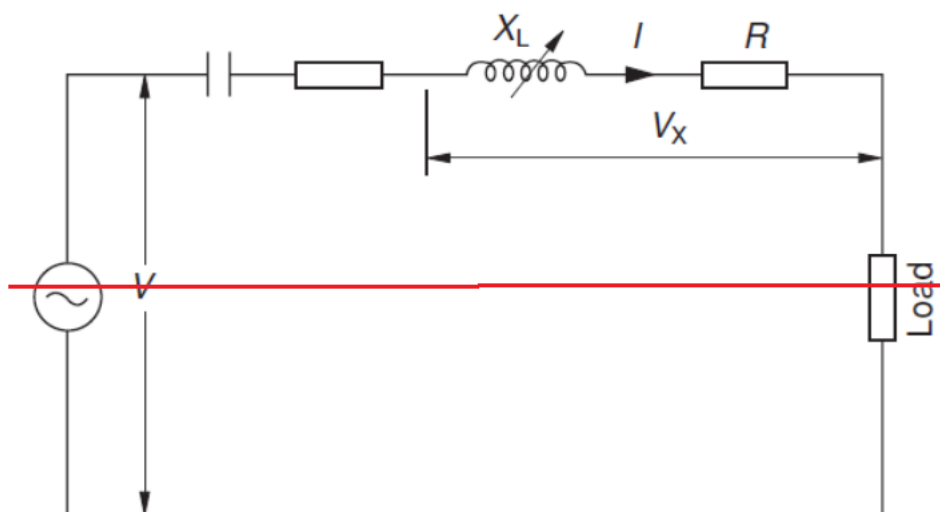

~~The CLR shall comply with Section 36.9. It must be ensured that the voltage available across the load does not fall below the permissible level as a result of the voltage drop across these CLR's. The CLR's shall be continuously rated.~~

**BSR/UL 2367, Standard for Safety for Solid State Overcurrent Protector****1. Recirculated changes for the Proposed Second Edition of UL 2367****PROPOSAL**

1.5 This Standard also covers devices intended to be used as limited power source current limiters in accordance with UL 62368-1, Audio/Video, Information and Communication Technology Equipment – Part 1: Safety Requirements, and UL 60950-1, Information Technology Equipment - Safety - Part 1: General Requirements. These devices limit output currents to values less than the ~~overcurrent protection~~ protective current rating of 5 amperes and a maximum output power of 100 VA.

**Table 10.2**  
**Maximum Acceptable Time for Protection Device to Trip**

| <b>Output voltage (<math>V_{oc}</math>)</b> | <b>Rated protective current (A)</b> | <b>Test current, Percent of rated <u>protective current</u></b> | <b>Maximum trip time (seconds)</b> |
|---|-------------------------------------|---|------------------------------------|
| $\leq 20$                                   | $\leq 5.0$                          | 210   | 120                                |
| $> 20$                                      | $\leq 100 / V_{oc}$                 | 210   | 120                                |

11.1 The device shall carry rated output maximum continuous current without tripping and the temperature rise during the test shall not exceed the maximum allowable temperature rating of the device or the rating of the insulating materials.

12.3 The output connections are to be loaded with a resistance value that will result in the device under test conducting at least 150 percent of its rated maximum continuous current until the device opens the circuit. Fifty operations of the device at this current level are to be conducted. One sample is to be cycled with the enable pin and another sample is to be cycled with the power pin.

## **BSR/UL 6703, Standard for Safety for Connectors for Use in Photovoltaic Systems**

### 1. Align the Voltage Rating for Both Single Pole and Multi-pole PV Connectors

1.3 This standard also covers latching or locking type multi-pole PV connectors rated ~~4000~~ 1500 Vac or dc or less. Multi-pole PV connectors consist of connectors, panel mounted connectors, distribution blocks and splitter connectors for the purpose of facilitating connections to and from inverters and like devices in a PV system.

**UL copyrighted material. Not authorized for further reproduction without prior permission from UL.**